



# OPERATING INSTRUCTIONS

DME20PU / DME20PW / DME20CW

Index 000

DME20PU

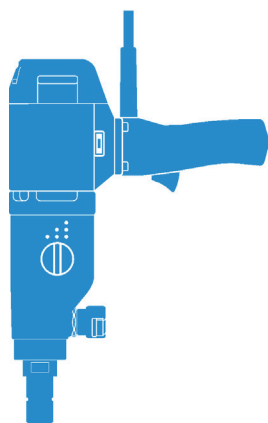

DME20PW

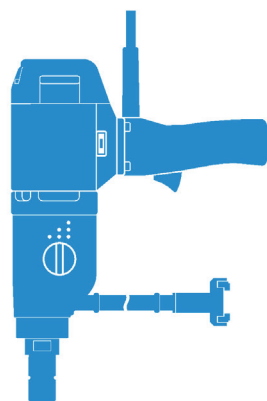

DME20CW

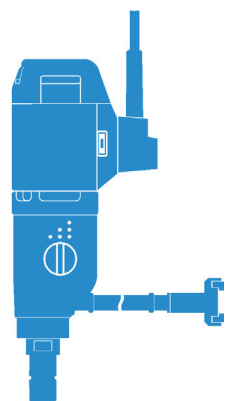

## Congratulations!

You have chosen tried and tested Tyrolit Hydrostress equipment that sets technological standards for the industry. Only genuine Tyrolit Hydrostress spare parts guarantee quality and problem-free replacement. If maintenance work is neglected or not performed correctly, we cannot cover our warranty obligations. All repairs must be performed by trained specialist personnel only.

Our Customer Service is at your disposal to help keep your Tyrolit Hydrostress equipment in perfect condition.

We wish you smooth, trouble-free working.

### **Tyrolit Hydrostress**

Copyright © Tyrolit Hydrostress

Tyrolit Hydrostress AG  
Witzbergstrasse 18  
CH-8330 Pfäffikon  
Switzerland  
Phone 0041 (0) 44 952 18 18  
Fax 0041 (0) 44 952 18 00

**[www.tyrolit.com](http://www.tyrolit.com)**

# Contents

<b>1. About these instructions</b>	<b>4</b>
1.1. Symbols in these instructions	4
<b>2. Safety</b>	<b>5</b>
2.1. General safety information	5
2.2. Protection devices and signs on the equipment	7
2.3. Spare parts and modifications	8
2.4. Danger zone and work area	8
2.5. Product-specific hazards	9
2.6. Residual risks	9
<b>3. Product description</b>	<b>11</b>
3.1. Core drilling system	11
3.2. Intended use	11
3.3. Scope of delivery	11
3.4. Technical data and main dimensions	12
3.5. Fluids and lubricants	13
3.6. Type plate	13
<b>4. Design and function</b>	<b>14</b>
4.1. Design	14
4.2. Function	14
4.3. Controls and display elements	15
<b>5. Assembly/disassembly</b>	<b>18</b>
5.1. Drill rig interface	18
5.2. Cutting tool interface	19
5.3. Power supply	19
5.4. Water connection	20
<b>6. Operation</b>	<b>21</b>
6.1. Settings	21
6.2. Starting/switching off the power tool	21
6.3. Monitoring, inspections	22
6.4. Troubleshooting	23
<b>7. Servicing and maintenance</b>	<b>24</b>
7.1. Recycling waste materials	24
<b>8. EC Declaration of Conformity</b>	<b>25</b>

## 1. About these instructions



This instruction manual is just part of the documentation for the power tool. This booklet is only complete together with the “core drilling safety manual/system description”.

This booklet together with the “Core drilling safety manual/system description” is part of the equipment. It describes safe and correct use in all operating phases.

- Carefully read the instructions, especially the safety information, before use.
- Keep the instructions throughout the lifetime of the equipment.
- Keep the instructions accessible to the operator and service technician at all times.
- Always pass on instructions to all future owners or users of the equipment.
- Update the instructions whenever you receive an update from the manufacturer.

### 1.1 Symbols in these instructions



#### **DANGER**

Warning of dangers which, if not avoided, can lead to severe or fatal injury.



#### **WARNING**

Warning of dangers which, if not avoided, can lead to injury or material damages.



#### **WARNING**

Warning of dangerous electric voltage.

Before working in an area with this warning, completely disconnect the system or equipment from the power supply (voltage) and secure so it cannot be inadvertently switched back on.



#### **INFORMATION**

Information for optimum use of the equipment. If this information is not heeded, the specifications in the technical data cannot be guaranteed.



#### **RECYCLING**

Recycling waste materials.



#### **DISPOSAL**

For disposal, pay attention to the usual regional and domestic laws and regulations in your country.

## 2. Safety



Core drilling systems may only be used by authorised personnel. You can find information on authorised personal in the “Core drilling safety manual/system description”.

### 2.1 General safety information



#### WARNING

Read all safety information and instructions. Failure to comply with the safety information and instructions may cause electric shock, fire and/or serious injury. Keep all safety information and instructions for future reference.



#### INFORMATION

The term “power tool” used in the safety information refers to mains-operated power tools (with mains cable) and battery-operated power tools (without mains cable).

#### 2.1.1 Workplace safety

- Keep your workplace clean and well illuminated. Disorganised or dark workplaces can lead to accidents.
- Do not work with the power tool in potentially explosive areas containing combustible liquids, gases or dust. Power tools generate sparks that can ignite dust or vapours.
- Keep children and other people away when operating the power tool. You risk losing control of the equipment if you are distracted.

#### 2.1.2 Electrical safety

- The plug for the power tool must fit into the socket. The plug must not be modified in any way. Do not use adapter plugs with earthed power tools. Unmodified plugs and the appropriate sockets reduce the risk of electric shock.
- Avoid physical contact with earthed surfaces such as pipes, heaters, stoves and refrigerators. There is an increased risk of electric shock if your body is earthed.
- Do not expose your power tool to rain or moisture. Ingress of water into a power tool can increase the risk of electric shock.
- Do not misuse the cable to carry the power tool or hang it up, or to pull the plug out of the socket. Keep the cable away from heat, oil, sharp edges or the moving device parts. Damaged or entangled cables increase the risk of electric shock.
- If you are working with a power tool outdoors, only use extension cables that are also suitable for outdoor use. Using an extension cable suitable for outdoor use reduces the risk of electric shock.
- Use a residual current circuit breaker if operating the power tool in a damp environment is unavoidable. Using a residual current circuit breaker reduces the risk of electric shock.

### 2.1.3 Personal safety

- When operating the power tool, be attentive, pay attention to what you are doing and use common sense. Do not operate power tools when you are tired or under the influence of drugs, alcohol or medication. A moment of carelessness when operating the power tool can lead to serious injury.
- Always wear personal protective equipment and protective goggles. Depending on the type and operation of power tool, wearing personal protective equipment, such as a dust mask, anti-slip safety shoes, hard hat or ear protection reduces the risk of injury.
- Avoid inadvertently putting the power tool into operation. Make sure that the power tool is switched off before connecting it to the power supply and/or battery, picking it up or carrying it. If your finger is on the switch when carrying the power tool or you connect the equipment to the power supply when switched on, it can lead to accidents.
- Remove any adjustment tools or wrenches before switching the power tool on. Do not work on a ladder. A tool or wrench in a rotating piece of equipment can lead to injury.
- Avoid working in an unnatural posture. Ensure that you have a secure footing and keep your balance at all times. This allows you to better control the power tool in unexpected situations.
- Wear suitable clothing. Do not wear loose clothing or jewellery. Keep hair, clothing and gloves away from moving parts. Loose clothing, jewellery or long hair can be caught by moving parts.
- If dust extraction and collection devices can be fitted, make sure that they are connected and used correctly. Using a dust extraction system can reduce hazards from dust.

### 2.1.4 Use and handling of the power tool

- Do not overload the device. Use the appropriate power tool for your work. With the appropriate power tool, you can work better and more safely in the specified power range.
- Do not use a power tool if the switch is faulty. A power tool that can no longer be switched on and off is dangerous and must be repaired.
- Disconnect the plug from the socket and/or remove the battery before making device settings, changing accessories or putting the device away. This precautionary measure prevents the power tool from unintentionally starting.
- When not in use, store the power tool out of the reach of children. Do not allow people to operate the device who are not familiar with it or who have not read these instructions. Power tools are dangerous when used by inexperienced people.
- Maintain power tools with care. Check whether moving parts are working properly and do not jam, and whether parts are broken or damaged in such a way that the function of the power tool is impaired. Repair any damaged parts before using the equipment. Many accidents are caused by poorly maintained power tools.
- Keep cutting tools sharp and clean. Carefully maintained cutting tools with sharp edges are less likely to jam and are easier to guide.
- Use power tools, accessories, insertion tools etc. in accordance with these instructions. Take the working conditions and the activity to be carried out into account. Using power tools for applications other than those for which they are intended can lead to dangerous situations.

### 2.1.5 Service

- Only have your tool repaired by qualified specialists, and only with genuine spare parts. This guarantees that the safety of the power tool is maintained.

### 2.1.6 Safety instructions for drilling machines

- Wear ear protection when using drilling machines. Exposure to noise can cause hearing loss.
- Use the additional handles supplied with the device. Loss of control of the machine can lead to injuries.
- Hold the device by the insulated gripping surfaces when carrying out work where the insertion tool may hit concealed power lines or its own power cable. Contact with a live wire can also make metal device parts “live” and lead to electric shock.

## 2.2 Protection devices and signs on the equipment

### Protection devices

Protection devices may only be removed when the equipment is switched off, has been disconnected from the mains supply and is stationary. Safety components, in particular, may only be removed and re-installed by authorised persons.

Safety elements must be checked to ensure they are in perfect working order before the equipment is brought back into operation.

### 2.2.1 Signs on the equipment

#### Safety sign



- 1 Read the instructions
- 2 Wear a helmet, goggles and ear protection
- 3 / 4 Conduct overhead drilling only with a suitable water catcher

#### Type plate

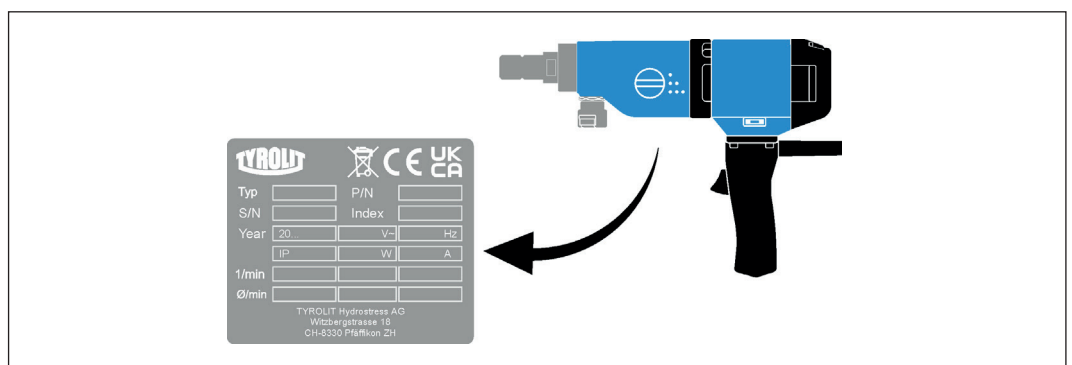

## 2.2.2 Personal protective equipment (PPE)

The wearing of PPE is essential for all work with and on floor core drilling systems.

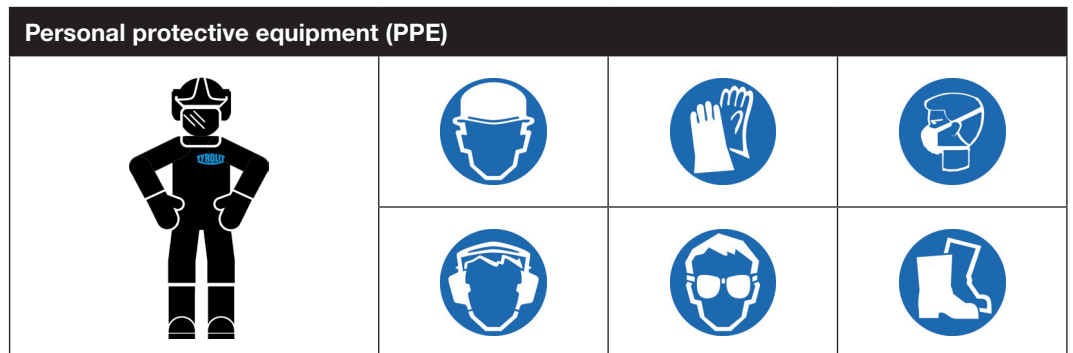

Personal protective equipment (PPE)

## 2.3 Spare parts and modifications

Only use genuine spare parts from Tyrolit Hydrostress. Otherwise personal injury, damage to the equipment and other material damages can occur. Do not install attachments on or convert the equipment without the written consent of Tyrolit Hydrostress.

## 2.4 Danger zone and work area

### 2.4.1 Danger zone on the power tool

The area marked in the drawing defines the danger zone of the power tool and the cutting tool. A minimum distance of 15 cm must be maintained during operation.

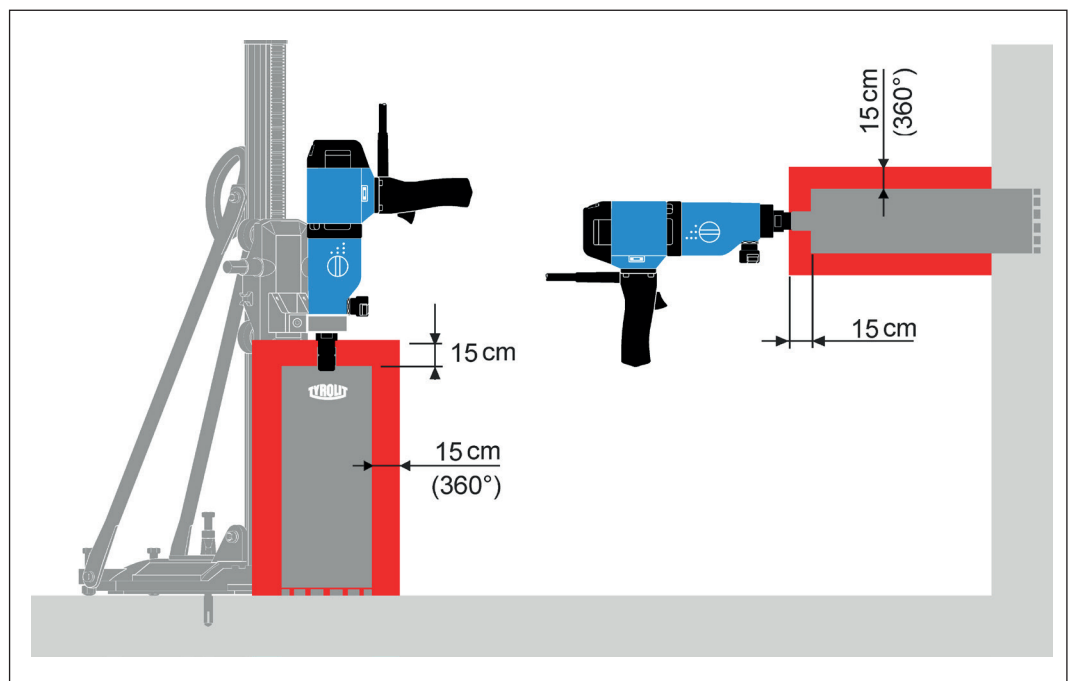

Danger zone on the power tool



## 2.4.2 Workstation danger zone



### INFORMATION

You can find information on the workstation danger zone in the “Core drilling safety manual/system manual”.

## 2.5 Product-specific hazards

### 2.5.1 Personal residual current protection device (PRCD, GFCI) – 230 V only

Only work with a functional personal residual current protection device (PRCD, GFCI).



Personal residual current protection device



### DANGER

There is a risk of death or serious injury if this is not observed.

- ▶ Do not expose your power tool to rain or moisture. Ingress of water into a power tool can increase the risk of electric shock.

### 2.5.2 Overhead drilling

- ▶ Drilling upwards (overhead drilling) in wet conditions is permitted only with a suitable water catcher.



## 2.6 Residual risks

There is a risk of severe injury resulting from the residual risks described below.

### 2.6.1 Diamond segments flying away

- ▶ Only start drilling when there are no other people in the danger zone.
- ▶ Make sure that a safety distance is complied with.
- ▶ If diamond segments break off, replace the diamond coring bit.

### 2.6.2 Uncontrolled movements and vibrations

- ▶ Do not connect or disconnect cables when the electric equipment is running.
- ▶ Always hold the portable drilling machine by the handles with both hands when switched on. Thumb and fingers must be closed around the handles.
- ▶ Keep the handles clean.

### 2.6.3 Vibrations

Vibrations can cause circulatory problems or nerve damage.

- ▶ Consult a doctor if symptoms occur.

### 2.6.4 Getting trapped and caught

Items of clothing or long hair could be caught by the rotating cutting tool.

- ▶ Do not wear loose clothing when working. Secure long hair in a hair net.

### 2.6.5 Harmful vapours and aerosol

Inhaling harmful vapours and aerosols can lead to respiratory problems. Inhaling water spray emanating from the machine is hazardous to health.

- ▶ Wear a respirator mask.
- ▶ Make sure that closed rooms have adequate ventilation.

### 2.6.6 Poor physical condition

- ▶ Do not work under the influence of alcohol, drugs or medication.
- ▶ Do not work when overtired.

### 2.6.7 Cutting tool quality

- ▶ Do not use damaged cutting tools.
- ▶ Check cutting tools for damage before assembly.

### 2.6.8 Danger from a cutting tool continuing to run in an accident

- ▶ Make sure that the electrical equipment can be stopped quickly.



#### **DANGER**

Not observing the safety information in the “safety manual/system manual” can result in death or serious injury.

- ▶ Make sure that the “Core drilling safety manual/system description” has been read and understood in full.

### 3. Product description

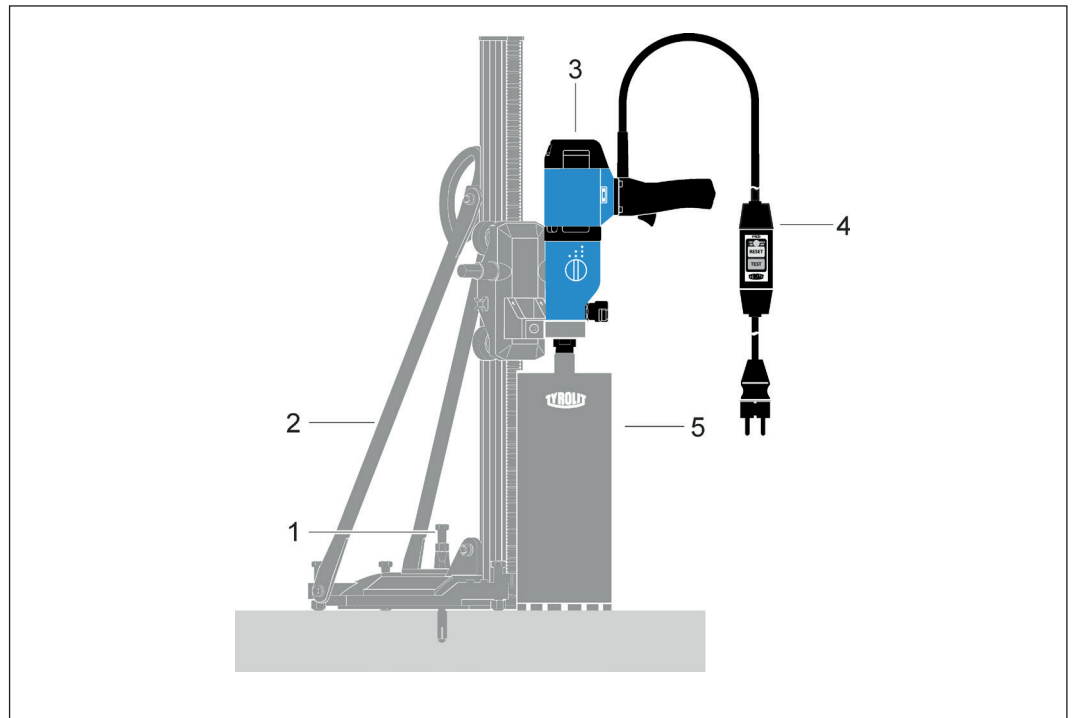

Core drilling system

- |                     |   |
|---------------------|---|
| 1 Mounting elements | 4 Personal residual current protection device (PRCD, GFCI) – 230 V only |
| 2 Drill rigs        | 5 Cutting tool  |
| 3 Power tool        |   |

#### 3.1 Core drilling system

This power tool forms a core drilling system in combination with suitable Tyrolit Hydros-tress components.

#### 3.2 Intended use

The DME20PW/DME20PU and DME20CW power tools are designed for rig-guided and hand-guided (only DME20PW/DME20PU) drilling of mineral substrates using diamond coring bits. When using the device for rig-guided drilling, a suitable drill rig must be used and sufficiently anchored to the surface by anchors, vacuum plates or quick-release supports.

Manipulating or modifying the device, drill rig and accessories is not permitted. Always use genuine Tyrolit Hydrosstress accessories and suitable tools to avoid the risk of injuries.

#### 3.3 Scope of delivery

- Drill motor
- Transport case (DME20PW/DME20PU only)
- Wrench SW32/SW22/SW24
- Operating instructions

### 3.4 Technical data and main dimensions

#### 3.4.1 Technical data

Drill motors	DME20PW		DME20PU		DME20CW	
Voltage	230 V	110 V	230 V	110 V	230 V	110 V
Frequency	50 Hz	60 Hz	50 Hz	60 Hz	50 Hz	60 Hz
Drilling diameter range	15-180 mm					
Nominal power	2.0 kW					
Nominal current	9.3 A	18.6 A	9.3 A	18.6 A	9.3 A	18.6 A
Load speed	540/1200/2520 rpm					
No load speed	900/1900/3900 rpm					
Motor cooling	Air					
Tool attachment (exterior)	1¼" UNC					
Tool attachment (interior)	G ½"					
Operation	Hand-operated/drill-rig guided					
Use	Wet		Wet/dry		Wet	
Electronic overload cut-out	Yes					
Mechanical overload cut-out	Yes					
PRCD circuit breaker	Yes					
Power display	Yes					
Service indicator	Yes					
Drill rig attachment	Clamping collar 60 mm					
Weight	6.7 kg		6.9 kg		6.4 kg	

#### Noise emissions and vibration

Noise data acc. to ISO 3744	
Parameter	Value
Noise pressure level $L_{pA}$	90 dB (A)*
Peak sound level pressure $L_{pCpeak}$	107 dB (A)
Sound power level $L_{WA}$	104 dB (A)*
Uncertainty K	3 dB (A)

Measurement conditions:

\* Ø 100 mm drill bit not in cutting mode at full load

Vibrations (EN ISO 5349)	
Parameter	Value
Whole-body vibration $a_{hv}$	< 2.5 m/s <sup>2</sup>
Uncertainty K	1.5 m/s <sup>2</sup>

### 3.4.2 Dimensions

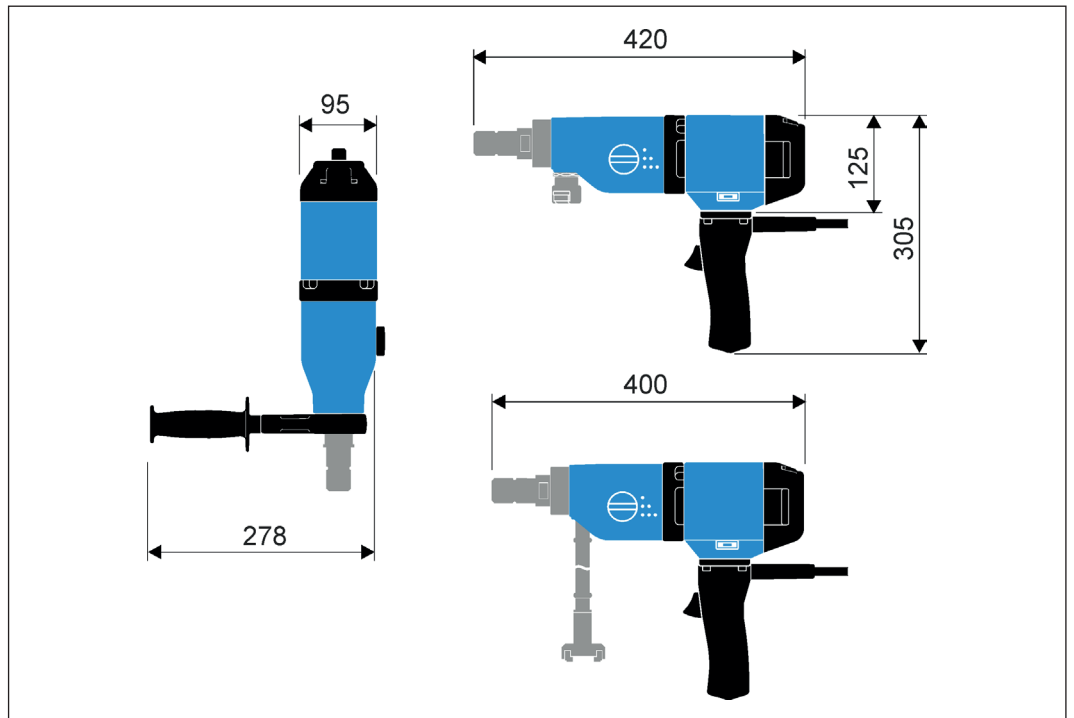

Dimensions in mm

### 3.5 Fluids and lubricants

Fluids and lubricants	
Parameter	Value
Transmission oil	ISO 100 (Tyrolit No.11008521/200ml)

### 3.6 Type plate

The type designation and serial number are marked on the type plate of your power tool.

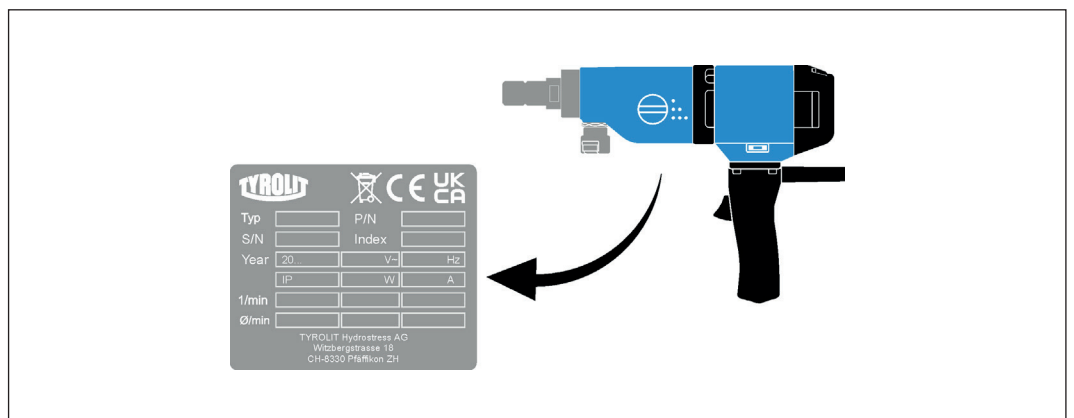

Type plate

## 4. Design and function

### 4.1 Design

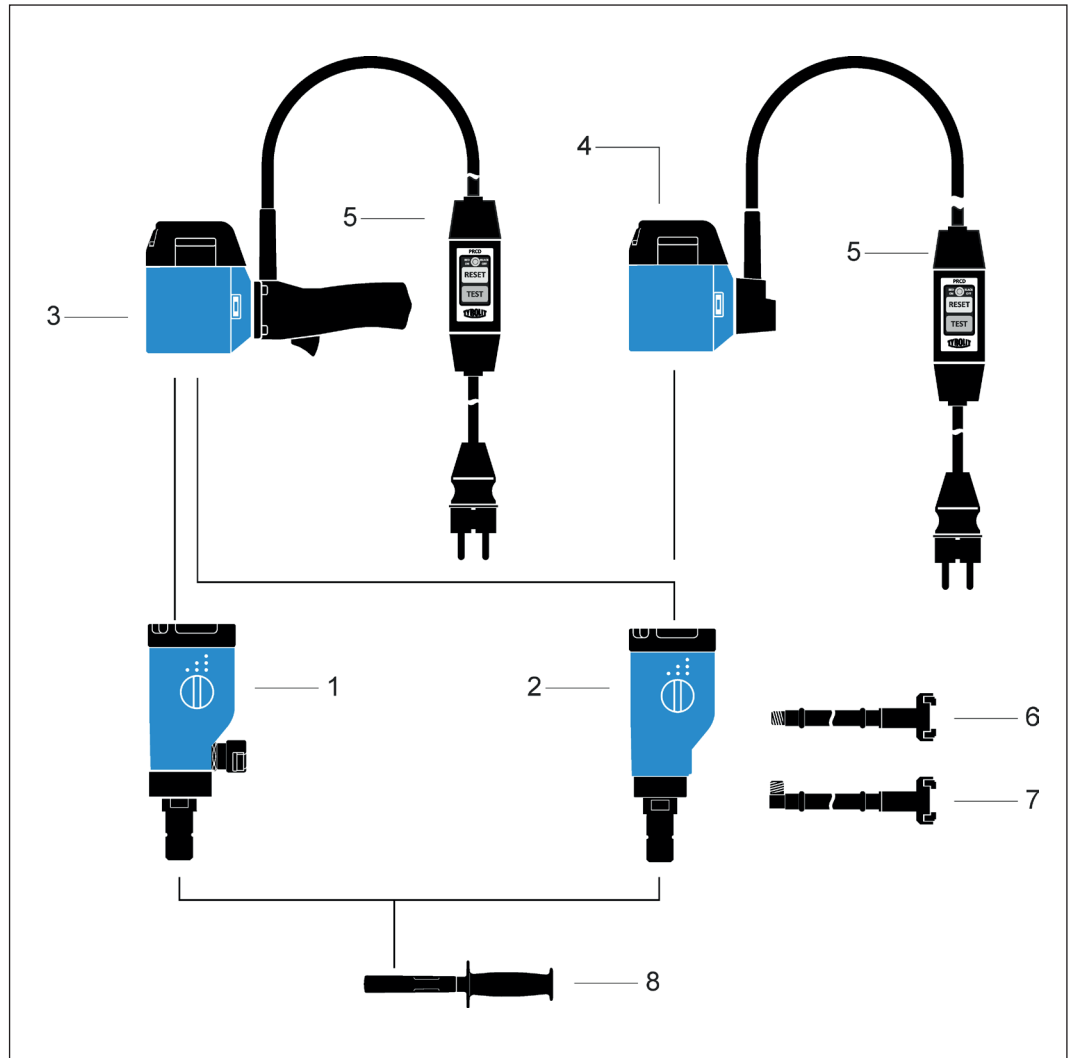

#### Design

- |                                |   |
|--------------------------------|---|
| 1 Transmission DME20PU         | 5 Residual current circuit breaker – 230 V only |
| 2 Transmission DME20PW/DME20CW | 6 Water connection DME20PW                      |
| 3 Motor DME20PU/DME20PW        | 7 Water connection DME20CW                      |
| 4 Motor DME20CW                | 8 Handle (DME20PU / DME20PW)                    |

## 4.2 Function

### 4.2.1 Functional description

The drill spindle of the power tool is driven by means of an electric motor via a mechanical transmission. The optimum speed of the cutting tool is set via the gears. The electric motor is air-cooled.

Working with the power tool is protected by a personal residual current protection device (PRCD, GFCI).

### 4.3 Controls and display elements

#### 4.3.1 Controls DME20PU/DME20PW

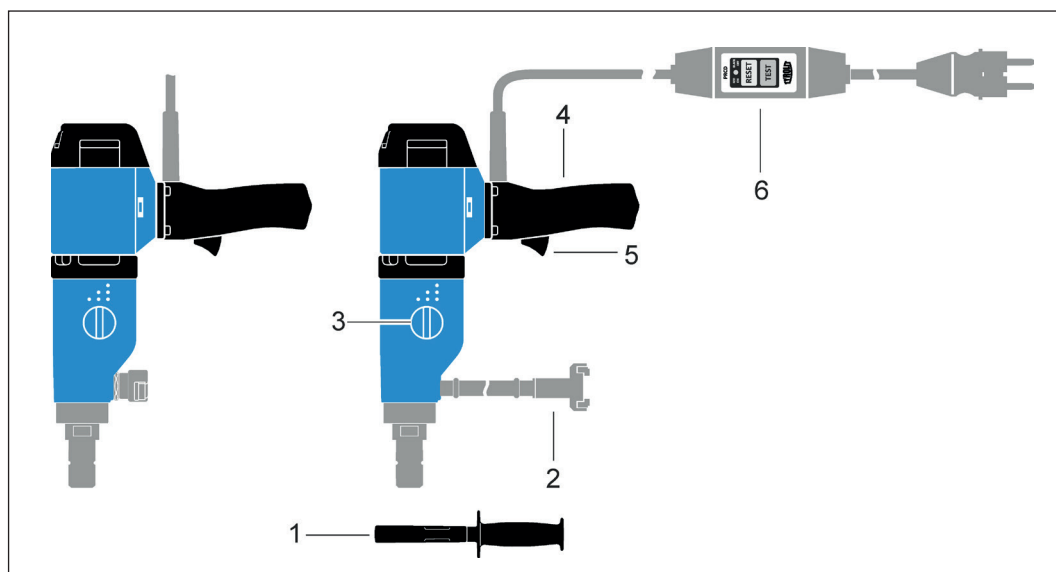

Controls

- |                                |   |
|--------------------------------|---|
| 1 Handle                       | 4 Operating handle                              |
| 2 Water tap main switch on/off | 5 Start switch                                  |
| 3 Rotary switch/gears          | 6 Residual current circuit breaker – 230 V only |

#### 4.3.2 Display elements DME20PU/DME20PW

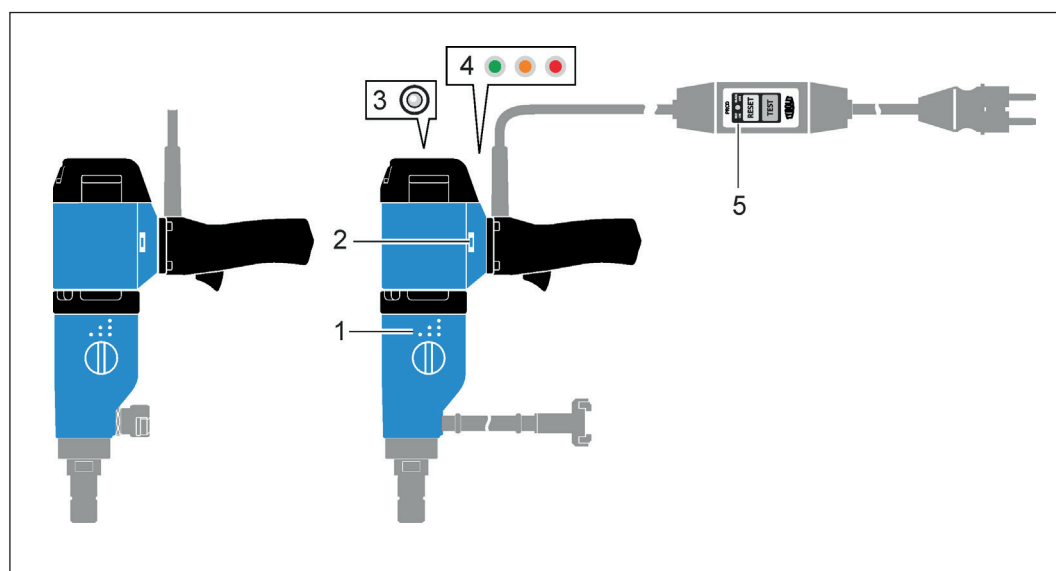

Display elements

- |                           |                                    |
|---------------------------|------------------------------------|
| 1 Gears marking           | 4 Light-emitting diodes            |
| 2 Vertical spirit level   | 5 PRCD display ON/OFF – only 230 V |
| 3 Horizontal spirit level |                                    |

### 4.3.3 Controls DME20CW

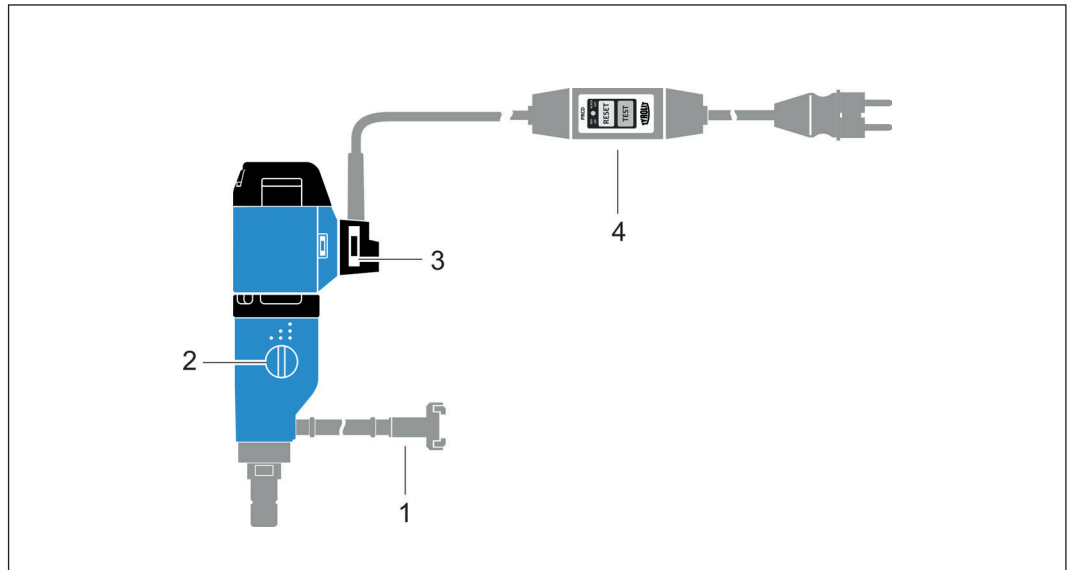

#### Controls

- 1 Tap
- 2 Rotary switch/gears
- 3 Main switch on/off
- 4 Residual current circuit breaker – 230 V only

### 4.3.4 Display elements DME20CW

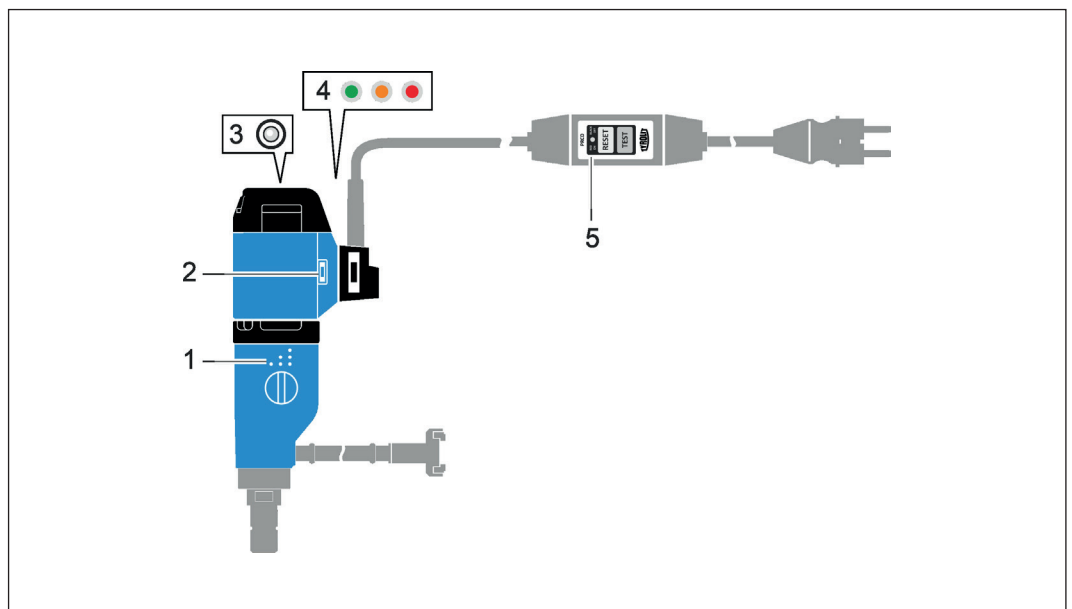













#### Display elements

- |                           |                                    |
|---------------------------|------------------------------------|
| 1 Gears marking           | 4 Light-emitting diodes            |
| 2 Vertical spirit level   | 5 PRCD display ON/OFF – only 230 V |
| 3 Horizontal spirit level |                                    |



**LED colour code**

Power display at standstill		
Green LED illuminates	  	Readiness
LEDs flash	  	Overload circuit

Power display in operation		
LED illuminates green	  	80% motor power
Light emitting diode illuminates	  	80%-100% motor power
Light emitting diode illuminates	  	>100% motor power
LEDs flash	  	Overload protection Speed is reduced and increased again in pulses

## 5. Assembly/disassembly

### 5.1 Drill rig interface

✓ Tool

Open-end  
wrench

Allen key

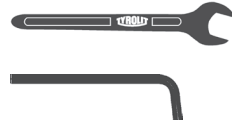

SW 24  
Tyrolit No. 973773

SW 6  
Tyrolit No. 973792

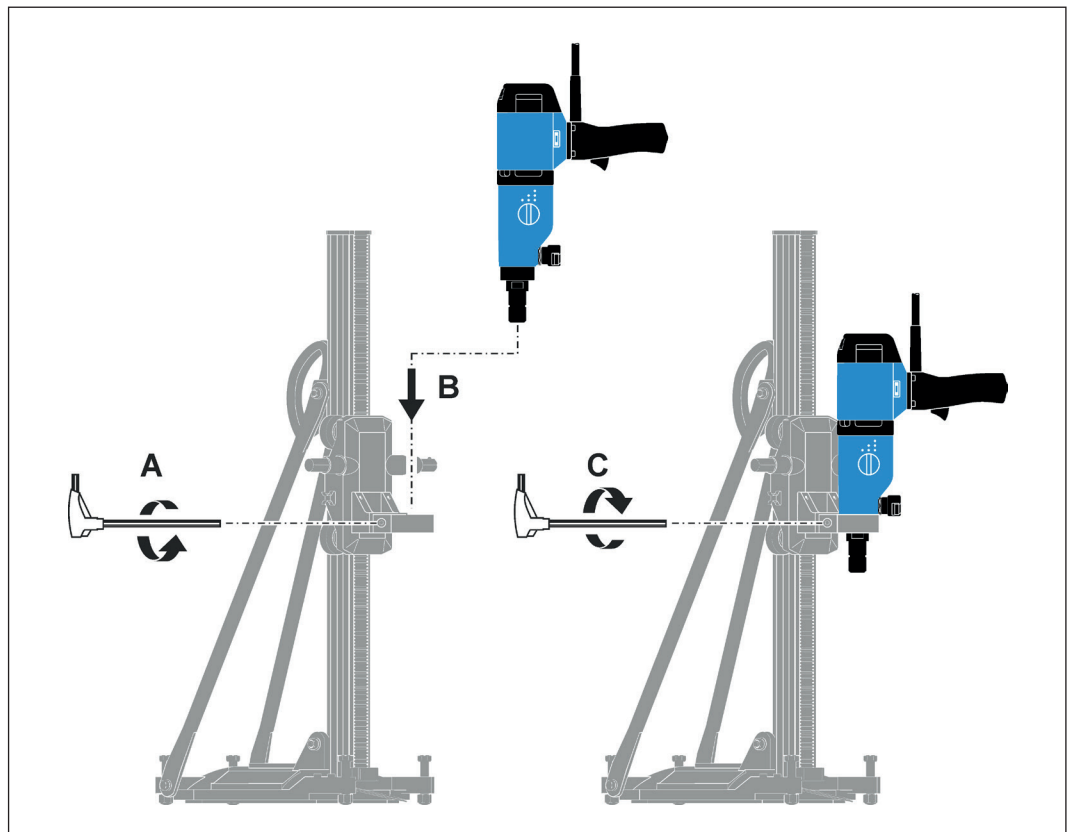

Drill rig interface

## 5.2 Cutting tool interface

✓ Tool

Open-end wrench



SW 22  
Tyrolit No. 973785

Open-end wrench



SW 32  
Tyrolit No. 980339

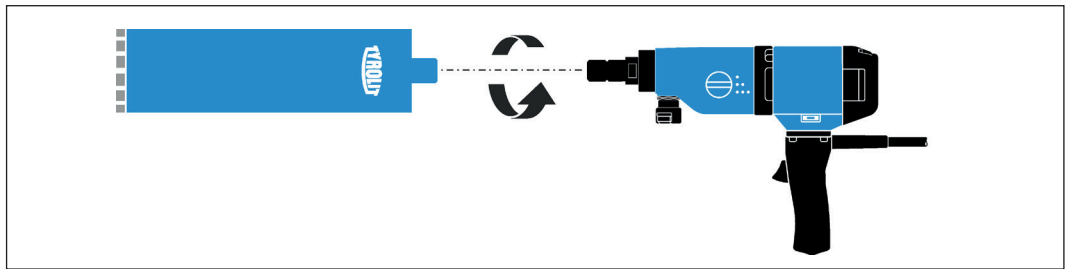

Cutting tool interface

## 5.3 Power supply



### INFORMATION

The mains voltage must match the specifications on the type plate.

- Protect the connecting cables against heat, oil and sharp edges.
- Only use the connecting cables for their intended purpose.
- Never carry the power tool by the connecting cable.
- Do not use the connecting cable to pull the plug out of the socket.
- In the event of power failures: switch off the power tool and pull out the plug.

### Extension cables



### INFORMATION

- Only use approved and appropriately marked extension cables outdoors.
- Avoid the use of extension cables with multiple sockets and the simultaneous operation of several devices.

Only use extension cables that are approved for the field of application and with an adequate cable cross-section.

Do not use extension cables with a conductor cross-section of 1.25 mm<sup>2</sup> (16 AWG).

Recommended minimum cross-sections and max. cable lengths				
Conductor cross-section mm <sup>2</sup>	1.5	2.5	4	6.0
110 V	not allowed	10 m	20 m	30 m
220 V-240 V	30 m	50 m	85 m	125 m

## 5.4 Water connection

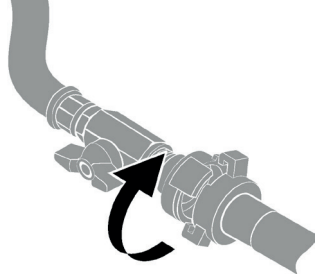

### 5.4.1 Cooling water

Cooling water				
Parameter	Value			
Hollow drill dia. in mm	52-152	162-202	212-300	350-450
Cooling water in l/min	1.0	1.5	2.0	2.5-3.0
Water connection	2 to 6 bar at max. 25°C			

### 5.4.2 Dry drilling



#### INFORMATION

Special Tyrolit diamond tools must be used for dry drilling.

### 5.4.3 Blowing out water

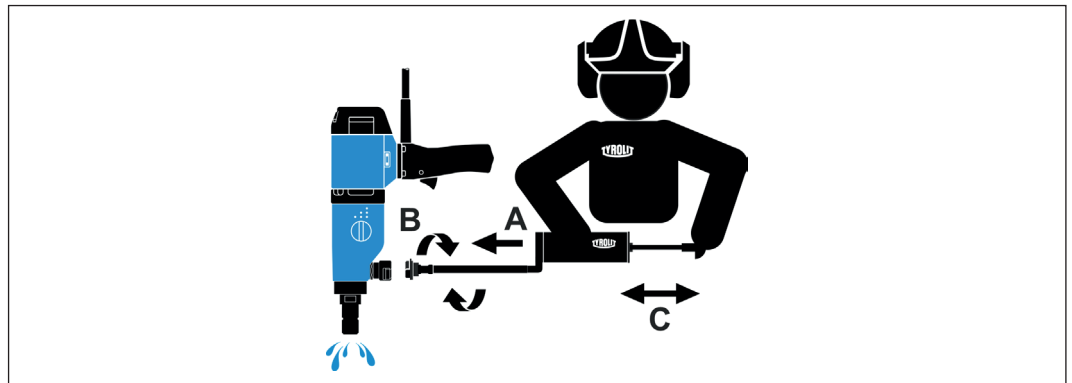

Blowing out water

Proceed as follows:

- ▶ Pull out the mains plug.
- ▶ Detach all water lines.
- ▶ Connect purge pump to the water coupling.
- ▶ Blow out water until all coolant has been removed.
- ▶ Remove the pump.



#### INFORMATION

Use the Tyrolit purge pump No. 10998115 so that the water can be blown out of the cables correctly.

## 6. Operation



### DANGER

- Never work without suitable PPE.
- Always wear ear protection during work.
- Remove adjustment and assembly tools before switching on the power tool.
- Do not work on ladders.
- Keep children away from the power tool and the working area.
- Avoid working in an unnatural posture.
- Ensure that you have a secure footing and keep your balance at all times.
- Avoid physical contact with earthed surfaces such as pipes, heaters, stoves and refrigerators. There is an increased risk of electric shock if your body is earthed.

### 6.1 Settings

#### 6.1.1 Transmission

Select the switch position according to the required drilling diameter. Never use force and only switch over when the electrical appliance is stopped or at a standstill.

#### 6.1.2 Water supply

Ensure there is a water supply.

### 6.2 Starting/switching off the power tool

- ✓ The power tool is correctly mounted on the drill rig.
- ✓ The cutting tool is bolted with inserted nuts securely to the power tool.
- ✓ The power tool is connected correctly to the power supply.
- ✓ The power supply was checked by means of a residual current circuit breaker PRCD.
- ✓ The water supply is ensured and the cutting tool is supplied with water.

- ▶ Start the motor using the on/off switch.
- ▶ The switch position can be fixed using the locking button (only DME20PU/DME20PW).

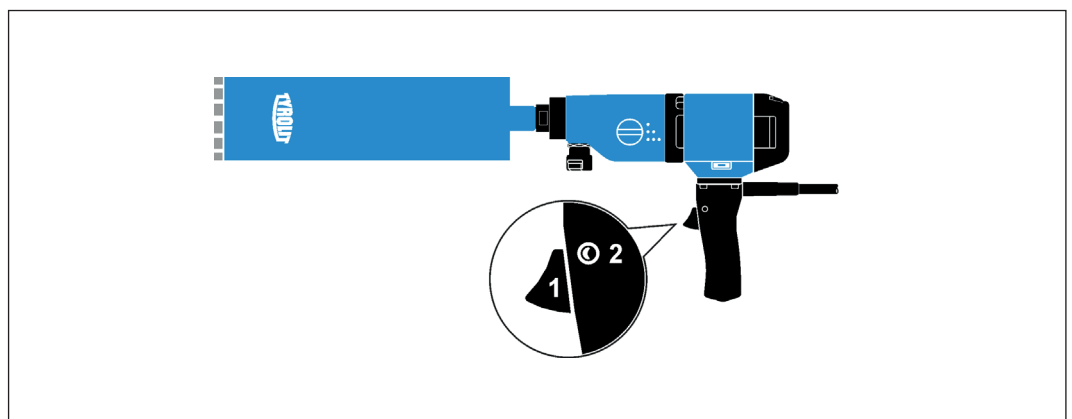

Starting the power tool

- 1 Start switch
- 2 Locking button

## 6.3 Monitoring, inspections

### 6.3.1 Residual current circuit breaker – 230 V only

- ▶ Switch on and inspect the PRCD residual current circuit breaker.

#### Inspection process:

- ▶ Insert the mains plug of the power tool into a socket outlet with an earth connection.
- ▶ Press the reset button on the residual current circuit breaker PRCD (display must illuminate).
- ▶ Press the push button on the residual current circuit breaker PRCD (display must vanish).



#### **DANGER**

If the display does not clear, the device must no longer be operated. The power tool must be repaired by qualified specialists using genuine spare parts.

- ▶ Press the reset button on the residual current circuit breaker PRCD (display must illuminate).



Residual current circuit breaker

## 6.4 Troubleshooting

<b>Troubleshooting</b>		
<b>Problem</b>	<b>Possible cause</b>	<b>Remedy</b>
Power tool will not start	Mains cable is faulty	Contact Tyrolit Hydrostress AG Customer Service
	Power supply faulty	Check the power supply
	Electric motor or electronics defective	Contact Tyrolit Hydrostress AG Customer Service
The power tool starts up, then switches off again	A fuse blows on the construction site power supply	Fuse protection too weak, change power supply
Motor runs, but the drill bit does not turn	Gear selector	Check position
	Transmission defective	Contact Tyrolit Hydrostress AG Customer Service
Cutting tool cannot be fitted	Thread dirty	Clean and grease the thread
	Thread defective	Contact Tyrolit Hydrostress AG Customer Service
Water leakage at the housing (relief hole)	Shaft seal defective	Contact Tyrolit Hydrostress AG Customer Service
Oil leakage at the housing (relief hole)	Shaft seal defective	Contact Tyrolit Hydrostress AG Customer Service
No water discharge	Water tap on supply line closed	Open the tap
	Water pipe is blocked	Clean the water pipe
	Water valve defective	Contact Tyrolit Hydrostress AG Customer Service
	Insufficient water pressure	Check the water circuit

## 7. Servicing and maintenance



**INFORMATION**

Always disconnect the mains plug before the start of maintenance or repair work.

Servicing and maintenance table							
		Each time before putting into operation	After the end of work	Weekly	Yearly	If problems occur	If damage occurs
Drive motor	<ul style="list-style-type: none"> <li>▶ Tighten loose bolts and nuts</li> <li>▶ Check cleanliness</li> </ul>	X				X	X
Drill bit mounting thread	▶ Grease			X			
	<ul style="list-style-type: none"> <li>▶ Check for damage</li> <li>▶ Check cleanliness</li> </ul>	X	X			X	X
Drill spindle	▶ Lubricate			X			
Cables, switches, plugs and connectors	<ul style="list-style-type: none"> <li>▶ Check for damage</li> <li>▶ Check cleanliness</li> </ul>	X	X			X	X
Water system	▶ Check that water line is clean and not leaking	X				X	X
	▶ Blow out water		X				
Service	▶ Have servicing work performed by Tyrolit Hydrostress AG or an authorised representative	<ul style="list-style-type: none"> <li>- Change gearbox oil after 100 hours</li> <li>- Check carbon brushes for wear after 300 hours and replace if necessary</li> </ul>					

### 7.1 Recycling waste materials



**INFORMATION**

Tyrolit Hydrostress power tools are manufactured using a large proportion of recyclable materials. Proper material separation is a prerequisite for recycling. In many countries, Tyrolit has already set up arrangements for returning your old equipment for recycling. Ask Tyrolit Customer Service or your sales advisor.





## 8. EC Declaration of Conformity

Designation	Electric drill motor
Type designation	DME20PU/DME20PW/ DME20CW

We declare under our sole responsibility that this product complies with the following directives and standards:

### Applicable directives

2006/42/EC	17/05/2006
2014/30/EU	26/02/2014
2012/19/EU	04/07/2012

### Applicable standards

EN ISO 12100:2010  
EN 62841-1:2015+AC:2015+A11:2011  
EN 62841-2 -1:2018+A11:2019 (PU/PW)  
EN 62841-3-6:2014+AC:2015+A11:2017 (CW)  
EN 55014-1:2021  
EN 55014-2:2021  
EN 61000-3-2:2019  
EN 61000-3-3:2013+A1:2019+A12:2021+A2:2021/AC:2022

**Tyrolit Hydrostress AG**  
Witzbergstrasse 18  
CH-8330 Pfäffikon  
Switzerland

Pfäffikon, 23/01/2024

Reto Schaffner  
Managing Director Technology



**TYROLIT CONSTRUCTION PRODUCTS GMBH**

Swarovskistraße 33 | 6130 Schwaz | Austria  
Tel +43 5242 606-0 | Fax +43 5242 63398

Our **worldwide subsidiary companies** can be found  
on our website at **[www.tyrolit.com](http://www.tyrolit.com)**