

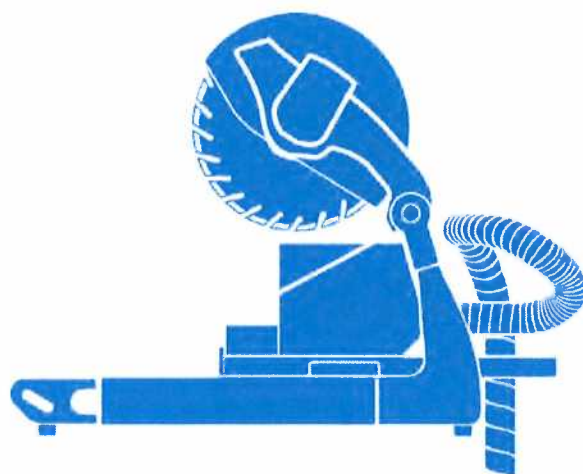

OPERATING INSTRUCTIONS

Chop Saw CSE350D

Index 000



Manufacturer's address:

TYROLIT Hydrostress AG

Witzbergstrasse 18

CH-8330 Pfäffikon

Switzerland

Tel. +41 (0)44 952 18 18

Fax +41 (0)44 952 18 00

www.tyrolit.com

TYROLIT Hydrostress AG reserves the right to make technical changes without prior notice.

Copyright © 2021 TYROLIT Hydrostress AG, CH-8330 Pfäffikon ZH, Switzerland

All rights reserved, in particular copyrighting and translating rights.

Printing of this operating manual, including extracts from it, is prohibited. No parts of it may be reproduced in any form or processed using electronic systems, duplicated or disseminated without the written permission of TYROLIT Hydrostress AG.

Contents

Table of Contents	1	Do's & Don'ts for Blades	15
		Wet Cutting Blades	15
		Dry Cutting Blades	15
Introduction	2		
Safety Precautions	2	Saw Maintenance	16
Job Site Safety	2	Cleaning the Saw After Use	16
Electrical Safety	3	Daily Inspection Before Use	16
Personal Safety	3	Temperature Changes	16
Safe Practices for Power Tool Use	3	Long Term Storage	16
Transporting Safety	4	After Long Term Storage	17
Service	4	Air Filter	17
		Carbon Brushes	17
Features	5		
		Transporting the Saw	18
Specifications	5		
		Troubleshooting Blade	19
Unpacking	6		
		Troubleshooting Saw	20
Assembly & Set Up	6		
		Notes	21
Saw Stand Assembly	6		
Folding Built-in Legs	6	Disposal	23
Deploying Built-in Legs	6		
		CE Conformity	33
Preparation for Use	7		
Choosing the Right Blade	7	Customer Service	24
Blade Installation	7		
Saw Stand	8		
Vacuum Table	10		
Constant Depth	11		
Rip Guide	11		
Electrical Specifications	11		
Extension Cord Chart	11		
Wiring Diagram	12		
Operating the Saw	12		
Wet Cutting	12		
Dry Cutting	13		
Plunge Cutting	13		
Transporting the Saw	14		

READ AND UNDERSTAND ALL INSTRUCTIONS. KNOW THE PRODUCTS APPLICATION, LIMITATIONS, AND POTENTIAL HAZARDS, PROTECT YOURSELF AND OTHERS BY OBSERVING ALL SAFETY INFORMATION. FAILURE TO FOLLOW ALL INSTRUCTIONS LISTED BELOW, MAY RESULT IN ELECTRIC SHOCK, FIRE, AND/OR SERIOUS PERSONAL INJURY. IN ADDITION MAY DAMAGE AND/OR IMPAIR ITS OPERATION AND VOID THE WARRANTY. RETAIN PRODUCT INSTRUCTIONAL MATERIAL FOR FUTURE REFERENCE.



Definitions

- ▲ **DANGER:** Indicate[s] a hazardous situation which, if not avoided, **will** result in **death or serious injury**.
- ▲ **WARNING:** Indicate[s] a hazardous situation which, if not avoided, **could** result in **death or serious injury**.
- ▲ **CAUTION:** Indicate[s] a hazardous situation which, if not avoided, **may** result in **minor or moderate injury**.
- NOTICE:** Indicates a practice **not related to personal injury** which, if not avoided, **may** result in **property damage**.

INTRODUCTION

Your Tyrolit power tool has been engineered and manufactured to our high standard for dependability, ease of operation, and operator safety. When properly cared for, it will give you years of rugged, trouble-free performance. Before using the power tool for the first time, inspect it to ensure no damage occurred during shipment. If damaged do not use and contact place of purchase for assistance.

SAFETY PRECAUTIONS

WARNING: Read all instructions written below. Failure to follow the warnings and instructions may result in electric shock, fire and or/serious injury.



WARNING!

Some dust created by power sanding, sawing, grinding, drilling and other construction activities contains chemicals known to cause cancer, birth defects or other reproductive harm. Some examples of these chemicals are:

- Lead from lead-based paints,
- Crystalline silica from bricks and cement and other masonry products, and
- Arsenic chromium from chemically-treated lumber.
- Cement and other masonry products.
- Di-Isononyl Phthalate (DINP).

Your risk from these exposures varies, depending on how often you do this type of work. To reduce your exposure to these chemicals: **ALWAYS** work in a well ventilated area, and work with approved safety equipment, such as those dust masks that are specifically designed to filter out microscopic particles.



JOB SITE SAFETY

- A. Be sure to connect the plug to a properly grounded receptacle to reduce the risk of electric shock.
- B. Before you start working, familiarize yourself with the work site and its surroundings.
- C. Take notice of circumstances which may impede work or traffic, observe soil conditions (good bearings or not) and take measures to ensure safety (e.g. the shielding of roadworks from public traffic).
- D. Keep work area clean and well lit.
- E. Keep out of reach of children. Before operating machine, be sure the activated machine will be of no danger to anyone.
- F. Do no expose power tools to rain or wet conditions.
- G. Never operate this unit when flammable materials or vapors are present. Electrical devices produce sparks or arcs which can cause a fire or explosion.
- H. Maintain alertness while operating the machine. Failure to maintain attention, by the operator, may lead to serious injury.
- I. Operate the power tool on a secure, level surface **ONLY**.

- J. When machine is plugged in do not leave it unattended.

ELECTRICAL SAFETY

- K. To reduce the risk of electrical shock, we recommend the use of ground fault circuit interrupter (GFCI) and to refer servicing to a qualified professional.
- L. If operating power tool in a damp location is unavoidable, use a ground fault circuit interrupter (GFCI) protected supply.
- M. Do not use the tool if the cord set is damaged or the ground fault circuit interrupter (GFCI) fails the before use test.
- N. Operate electric motor only at the specified voltage indicated on the nameplate.
- O. Avoid body contact with earthed or grounded surfaces such as pipes, radiators, ranges and refrigerators.
- P. When using an extension cord, make sure it is in good condition and heavy enough to carry the current drawn by the machine. Refer to the extension cord table in the "Electrical Specifications" section for the correct gauge depending on the desired cord length and the machine's horse power and voltage.
- Q. Use extension cable suitable for outdoor use when operating power tool outdoors.
- R. Power tool plug must match the outlet. Never modify the plug in any way. Do not use any adapter plug with earth(grounded) power tools.
- S. Do not use the power tool if the switch does not turn it on and off.
- T. Unplug prior to servicing.
- U. Never disconnect any emergency or safety devices. These devices are intended for operator safety. Disconnection of these devices can cause severe injury, bodily harm or even death. Disconnection of any of these devices will void all warranties.
- V. Do not spray water onto electric motor.
- W. Never let power cords or cables lay in water.
- X. Never grab or touch a live power cord or cable with wet hands. The possibility exists of electrical shock, electrocution or death.

PERSONAL SAFETY

- Y. Do not operate the machine when you are tired or while under the influence of drugs, alcohol or any medication.
- Z. Do not overreach. Keep proper footing and balance at all times.
- a. When operating the saw, be sure to wear proper safety gear, such as safety glasses, dust mask, and hearing protection. A hard hat is also recommended.
- b. Wear proper apparel. Do not wear loose clothing or accessories. Keep hair and body parts away from

openings and moving parts.

- c. Make sure power switch is in "off" position before plugging in power cord to prevent any accidental activation.
- d. Keep hands away from moving parts at all times.
- e. Never lift the power tool while the motor is running.

SAFE PRACTICES FOR POWER TOOL USE

- f. To adhere to OSHA Table 1 for Working with Materials Containing Crystalline Silica with a stationary masonry saw ALWAYS use the optional water delivery system that feeds water continuously to the blade.
- g. Never use the machine improperly or work in an unsafe manner.
- h. Wet cutting blades MUST be used with water.
- i. Do not force the power tool. Use the correct power tool for your application.
- j. To mount the blade, clean and inspect the arbor, flanges and bolts for damage. Do not use if damaged. If no problems found tighten the bolt/nut securely.
- k. Remove any adjusting key or wrench before turning the power tool on.
- l. Unplug prior to servicing, when changing accessories, and when not in use.
- m. Saw blades should be inspected daily for excessive wear, core cracks and arbor damage. Replace any blade that shows signs of damage.
- n. A visual check of the machine must be made at least once a shift to ensure that visible damages or faults are recognized. Any changes (including changes in the performance or behavior of the machine) must be investigated and repaired immediately.
- o. Do not use damaged blades. Before each use, inspect the wheels for chips and cracks. If power tool or blade is dropped, inspect for damage or install an undamaged blade. After inspecting and installing the blade, position yourself and bystanders away from the plane of the rotating wheel and run the power tool at maximum no load speed for one minute.
- p. Wait for the blade to reach the maximum speed and use a slow feed for proper cutting.
- q. Ensure the blade is marked with an operating speed greater than the spindle speed of the saw.
- r. Never transport machine by cord. Do not pull cord to unplug. Keep cord away from heat, sharp edges and oil.
- s. Take measures to ensure that the machine is in a safe and trouble-free condition prior to usage. use the machine only when all protective devices (i.e. guards, noise absorbers, emergency-off devices) are

- in place and in working order.
- s. Make sure power switch is in "off" position before plugging in power cord to prevent an accidental activation.
- t. In the case of a malfunction, stop the machine immediately and secure it. Fix the problem as soon as possible.
- u. Keep the power cord away from the spinning blade.
- v. Do not modify guards.
- w. Wait until the spinning blade comes to a complete stop before accessing material being cut.
- x. Always check the power tool for loosened threads or bolts before starting.
- y. Never use accessories or attachments that are not recommended by Tyrolit for this power tool. Damage to the power tool and/or injury to the user may result.
- z. Tyrolit does not assume responsibility for any accident due to equipment modifications. Unauthorized equipment modification will void all warranties.
- 1a. Accidental starting can cause severe injury or death. ALWAYS place the ON/OFF power switch in the OFF position.
- 1b. Ensure the blade is mounted for proper operating direction.

TRANSPORTING SAFETY

- 1c. Never allow any person or animal to stand underneath the power tool while it is being transported.
- 1d. Use proper heavy lifting practice when transporting the power tool.
- 1e. Always shutdown motor before transporting.
- 1f. Never transport the power tool with the blade mounted.
- 1g. Always tie down the power tool during transport by securing the equipment with rope.

SERVICE

- 1h. Only qualified repair person, using original replacement parts, should be servicing this power tool.

Features

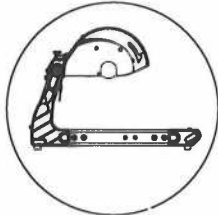

Frame Assembly

Solid steel and die-cast rigid aluminum frame provides rigidity and strength to minimize vibration and maximize longevity of the saw.

Open-back Design

Allowing material to pass between the frame posts allow for longer material sizes.



Folding Stand (Optional)

All steel compact folding stand is available to support the saw at a comfortable working height.

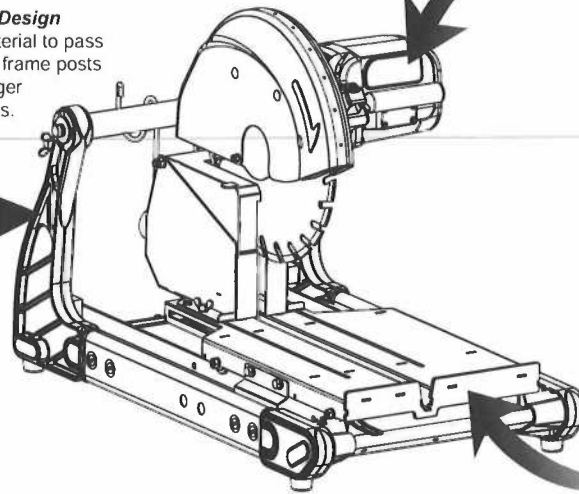

Carbon Brush Motor

Dependable 3HP motor that can generate a tremendous amount of torque while minimizing power loss to the blade shaft through the built-in gear box.

Motor Filter

Motor fan cover includes a filter for cleaning all air that passes through the motor.

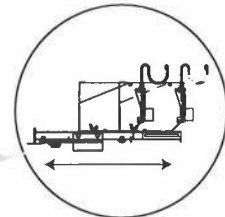

Vacuum Table

All steel vacuum table to handle every day use as well as an adjustable sliding vacuum attachment for maximum suction efficiency.

Specifications

	Motor	Max. Blade Capacity**	Cutting Length	Cutting Depth	Weight	Dimensions
CSE350D	2.2 KW 230 V / 50 Hz 3600 RPM	350 mm blade 25.4 mm (1") arbor	400 mm	125 mm	34 kg	Length: 865 mm Width: 510 mm Height: 510 mm

* Dimensions do not include extension tables and drip trays.

** Always use a 14-in blade. A smaller size blade may grab the material being cut, causing damage to the equipment and injury to the operator.

Unpacking

CAUTION: When lifting saw out of the box, two people are required. Practice safe lifting behavior when carrying heavy objects. Wear back brace as necessary. **DO NOT** use open toe shoes.

Open the container and carefully lift the saw out of the packaging and place it on a flat, level working area. Be sure that you have the following items before you discard the container:

1. Saw
2. Rip guide
3. Replacement filter
4. Wrenches (universal, open and hex wrench)
5. Manual
6. Water hose assembly (optional)
7. Blade
8. Spare filter

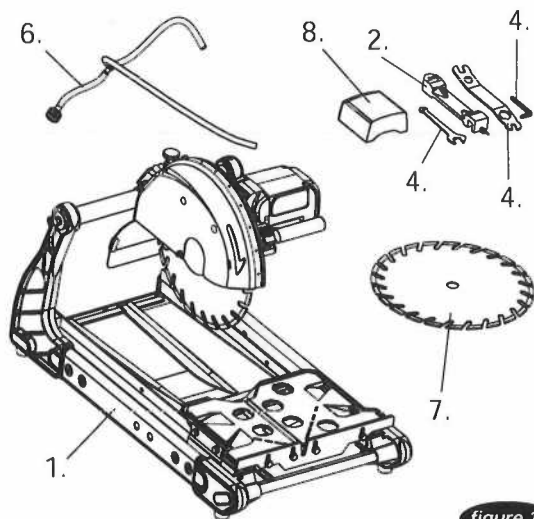

figure 1

*Actual appearance may vary.

Assembly & Setup

WARNING: Read all instructions written below. Failure to follow the warnings and instructions may result in electric shock, fire and/or serious injury.

1. Raise the cutting head to the horizontal position by using one hand to grab the plunge handle while the free-hand pulls on the cutting head lock. (see figure 2)

2. Once head is in proper position release cutting head lock, then pull on the plunge handle to confirm cutting head is locked into desired position.
3. Remove packaging block that was supporting the cutting head.

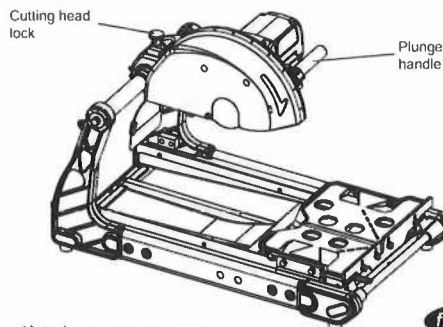

figure 2

*Actual appearance may vary.

4. Remove the hose cap, hose clamp and hose clamp screws on the blade guard. (see figure 3)
5. Position the water hose assembly as shown in figure 3 and clamp down on it using the provided hose clamp and the original hose clamp screws.
6. Insert the hoses into the blade guard. (see figure 3 and 4)
7. Strap assembly using provided straps. (see figure 4)

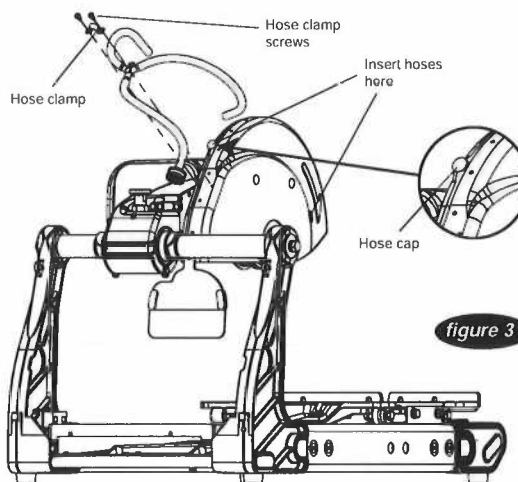
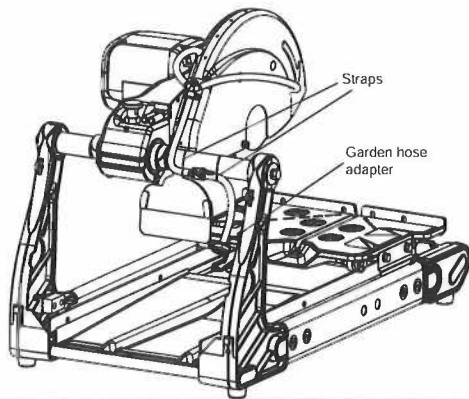

figure 3

*Actual appearance may vary.

WARNING: Water pressure going to the water hose assembly should not exceed 5,6 bar.



*Actual appearance may vary.

figure 4

Preparation for Use

CHOOSING THE RIGHT BLADE

NOTICE: ALWAYS dress/sharpen the blade when cutting speed is reduced as it may lead to poor cutting accuracy. Always let the blade cut, do not force.

CAUTION: Wet cutting blades must be used with water to prevent premature/sudden failure.

1. The blade shaft speed of this saw is exclusively designed for cutting with diamond saw blades. The saw may only be used for cutting natural and artificial stone materials, do not cut wood or metal!
2. Choose the correct type of saw blade for the material to be cut and the required cutting depth.

BLADE INSTALLATION

WARNING: Disconnect the power plug before installing the blade onto the blade shaft.

WARNING: ALWAYS inspect the blade, flanges and shaft for damage before installing the blade. Failure to thoroughly inspect the blade can result in damage to the saw and serious personal injury.

NOTICE: ALWAYS match the arbor on the inner flange to the bore size on the blade. It is important that the blade fits snugly onto the inner flange to prevent serious blade damage. Poor blade seating will result in lopsided wear and burnt or oblong bore hole. If the arbor shoulder of the inner flange becomes worn from blade slippage, replace the flange.

1. Open the blade shaft cover.
2. Remove the blade shaft lock bolt, washer and outer flange. (see figure 5)
3. If a blade has been mounted hold the blade with one hand or use the provided open wrench to hold the blade shaft in place. To hold the blade shaft insert the open wrench into the slot on the blade shaft behind the inner flange. With the free-hand use the universal wrench to loosen the blade shaft lock bolt by rotating it in the direction indicated on the blade guard. (see figure 5)
4. Place the 14-inch blade onto the arbor of the inner flange.
5. Reassemble the outer flange, washer and blade shaft bolt. When bolt is tight the blade should not wobble or have any play. It should only rotate about the blade shaft axis.
6. Close the blade shaft cover.

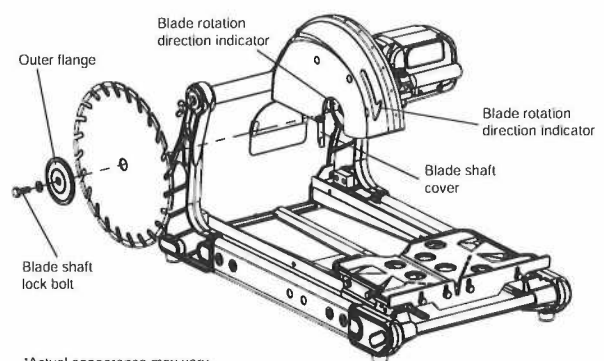

*Actual appearance may vary.

figure 5

SAW STAND (OPTIONAL)

⚠ CAUTION: Practice safe lifting behavior when carrying heavy objects. Wear back brace as necessary. **DO NOT** attempt to lift the saw by yourself, two people are required. **DO NOT** wear open toe shoes.

⚠ WARNING: The following steps should be done on a stable dry flat surface.

⚠ WARNING: Lock the table before proceeding to prevent damage or bodily harm from sudden movement of the table.

⚠ WARNING: Disconnect the power plug before modifying/servicing the saw.

1. Position the stand upright such that the wedge shaped feet are touching the ground *as shown in figure 6*.
2. Pull out the lock pins from position A and open up the frame to form an "X". *(see figure 6)*
3. Fold out the table and put the lock pins into lock pin position B. *(see figure 6)*

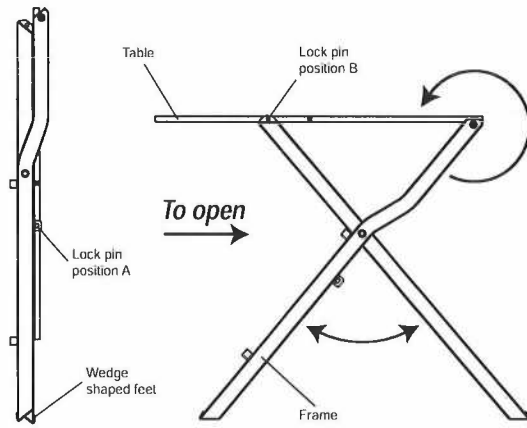
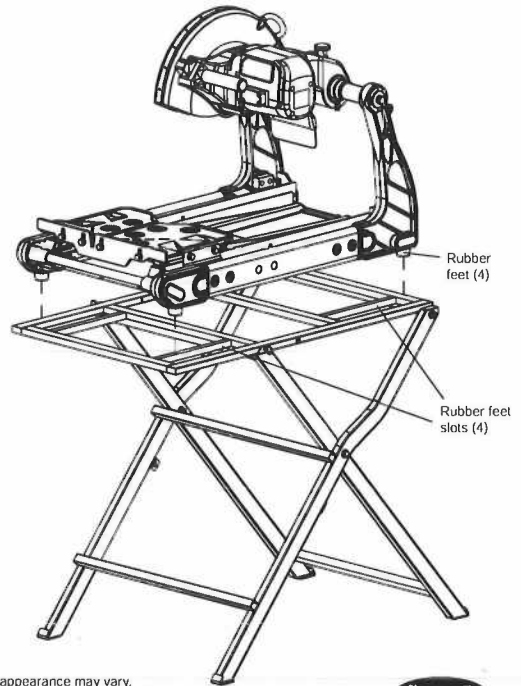

figure 6

4. Place the saw on the support stand. *(see figure 7)*
Make sure the saw's rubber feet are seated securely in the corresponding slots in the stand. The saw frame **MUST** be sitting flush with the stand table.



*Actual appearance may vary.

figure 7

VACUUM TABLE

- ⚠ WARNING:** Disconnect the power plug before modifying/servicing the saw.
- ⚠ WARNING:** Only use 350 mm blades for this saw. Setting smaller size of diamond blade may grab the material being cut, causing damage and possibly injury.
- ⚠ WARNING:** Lock the table whenever the saw is not in use or is being transported.
- CAUTION:** Only use vacuums with 250 m³/h or stronger.

1. Check the cutting table cannot be lifted from the rails. To check attempt to lift the table away from the rails. If the table can disengage from the rails the table brackets need to be adjusted. (see figure 9)
2. Each bracket (2) is held in place by two bolts. Adjust the brackets by loosening the bolts (2) and pulling the bracket up before retightening the hardware. The bracket should not come into contact with the rail.
3. To unlock the table from the rail push the table lock inwards towards the center of the saw as shown in figure 9. Do the reverse to lock the table.
4. Push the table to the back of the saw.
5. Remove the hardware already mounted on the table and attach the sliding vacuum attachment. (see figure 9)
6. Reattach the removed hardware using guideline as shown in figure 10.

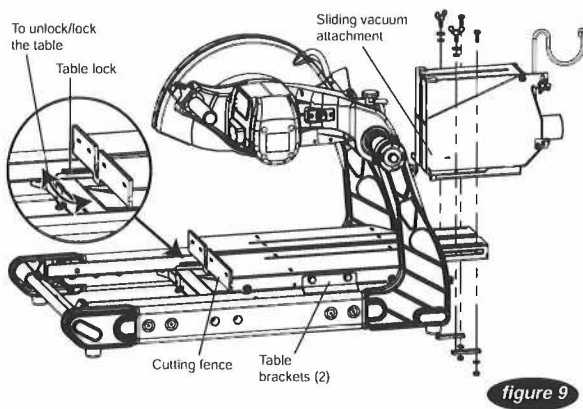
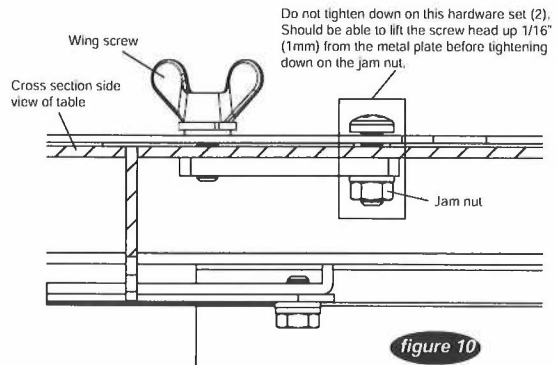

7. The vacuum hood can be set to (see figure 11):
 - 7a. Raise and lower on its own by loosening the wing screw (1) on the back of the sliding vacuum attachment where the vacuum hose is, maximizing vacuum coverage even when cutting thin long material like pavers. Note that the vacuum hood will lower whenever the blade guard impacts it during a plunge cut.
 - 7b. Always be set in the lowered position when plunge cutting short thin materials like bricks by loosening the wing screw (1), pushing the vacuum hood down and then retighten the wing screw (1) on the back of the sliding vacuum attachment where the vacuum hose is.

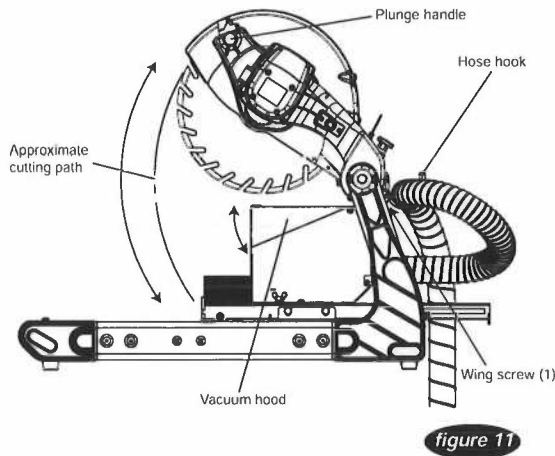

figure 11

CAUTION: Do not adjust the material being cut on the table while blade is in motion!

8. The sliding vacuum attachment can be moved forward or backwards with respect to the cutting table by loosening the wing screws (2) at the base of the attachment, moving the sliding vacuum attachment to hug the cutting material and then retightening the wing screws (2) (see figure 12).

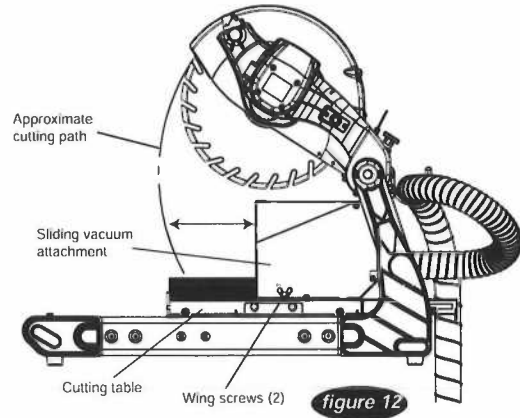

figure 12

CAUTION: Do not adjust the material being cut on the table while blade is in motion!

CUTTING DEPTH

WARNING: Disconnect the power plug before modifying/servicing the saw.

CAUTION: Only release the plunge handle when FINISHED adjusting the cutting head position.

The CSE350D masonry saw is designed with three different cutting heights for jam cutting, a moving head for chop (or plunge cutting), and a moving cart combined with the moving head for step cutting to help make any cutting task easier.

Head Position	Fixed Upper	Fixed Middle	Fixed Lower	Moving Head & Table
Application	Diamond blade replacement	Jam cutting blocks	Jam cutting bricks	Step cutting

1. To adjust the angle lock pin, firmly hold the plunge handle and pull on the head of the pin. If the pin does not move, push the plunge handle down slightly until the pin unbinds. (see figure 11 and 13)
2. Raise or lower the cutting head as desired.
3. The angle lock pin can be set to:
 - 3a. Return to the locked state by releasing the head of the pin allowing the pin to return to its original state. Note that if the angle lock pin does not fully seat when returning to its original position, push and pull on the plunge handle until it does.

- 3b. Remain in the unlocked state by turning the head 90-degrees so that the head of the pin remains raised. If cutting small bricks the cutting table can be locked in the plunge cutting position for more ease of cutting. (see figure 13)

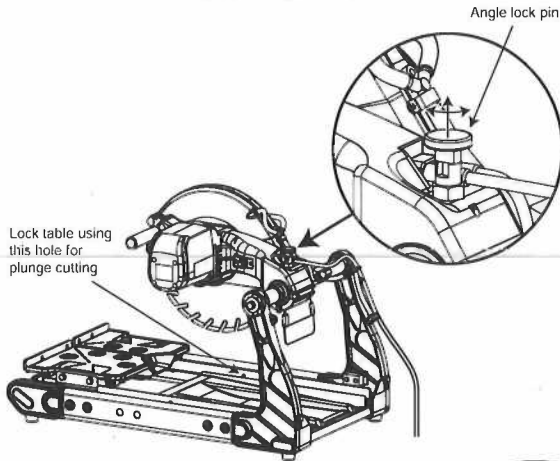

*Actual appearance may vary.

figure 13

RIP GUIDE

⚠ WARNING: Disconnect the power plug before modifying/servicing the saw.

⚠ WARNING: Lock the table whenever the saw is not in use or is being transported.

The cutting table has a metal cutting fence for material to rest against when performing a cut. If there is a need to make repeat cuts or if the material is large and needs additional support, the included rip guide can be used in conjunction with the cutting fence to perform accurate 45-degree and 90-degree cuts. (see figure 14)

1. Measure how much to cut off the material using the cutting fence and blade as reference and place on the cutting table, against the cutting cutting fence. If cutting at 45-degrees move the wing screw to the other side of the rip guide.
2. Place the rip guide against the left side of the table as shown on figure 14.
3. Tighten the wing screw. The rip guide should not be able to move.

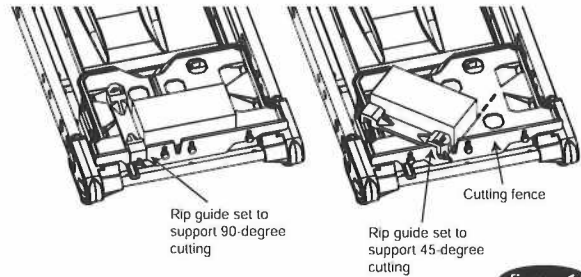

*Actual appearance may vary.

figure 14

Electrical Specifications

⚠ DANGER: Disconnect the power plug before modifying/servicing the saw.

	CSE350D
Power	2.2 KW
Volts	230 V
Amps	10 A
Blade Shaft RPM	3600 RPM
Cycle	50 Hz
Phase	1

EXTENSION CORD CHART

⚠ DANGER: ALWAYS use a grounded (3-pole) extension cord and MAKE SURE the motor is connected to a properly grounded electrical outlet. Whenever possible, use a GFCI receptacle to reduce the risk of electrical shock.

⚠ DANGER: NEVER use a damaged or worn extension cord when connecting to a power source. A defective cord can cause damage to the electrical motor and electrical shock to the operator.

NOTICE: When using extension cable follow the chart shown below. Table shows the correct size to use depending on cord length. If in doubt, use the next heavier gauge.

Wire Gauge	Length of Cord
1.5 mm ²	30 m
2.5 mm ²	50 m
4.0 mm ²	80 m

RECOMMENDED

1. It is recommended that a 10 amp circuit be used while operating this saw. This will prevent any loss of power or interruption.
2. Always plug saw as close as possible to the power source while operating. This will allow you to receive optimum electricity.

⚠ WARNING: Water may travel along the power cable and come into contact with the receptacle. The user should arrange a "drip loop" in the cord that is connecting the power tool to the receptacle such that the "drip loop" hangs lower than the receptacle itself (see figure 15).

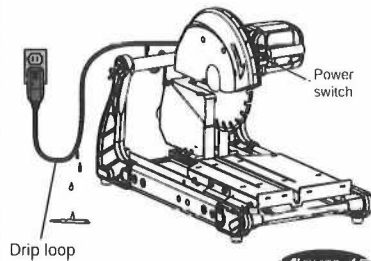

figure 15

⚠ CAUTION: Before plugging in tool, always check to see that the switch is in the OFF position.

NOTE: READ AND UNDERSTAND ALL INSTRUCTIONS. KNOW THE PRODUCTS APPLICATION, LIMITATIONS, AND POTENTIAL HAZARDS. PROTECT YOURSELF AND OTHERS BY OBSERVING ALL SAFETY INFORMATION BEFORE USING THE SAW.

⚠ WARNING: Severe bodily harm may occur if hands or fingers come into contact with the rotating saw blade. NEVER place hands or fingers near the cutting blade.

⚠ WARNING: NEVER raise the blade guard while the blade is rotating. ALWAYS wait for the blade to stop rotating before raising the blade guard. NEVER operate the saw with the blade guard removed.

⚠ WARNING: ALWAYS verify that the cutting blade has been installed correctly before using the saw.

⚠ WARNING: NEVER exceed the maximum RPM. Poor saw performance, damage to the blade, and serious injury or death may occur as a result.

⚠ DANGER: ALWAYS be aware of the rotating blade in relation to the position of your body ESPECIALLY your hands. Severe bodily harm or death can occur if your body comes into contact with the rotating saw blade.

⚠ WARNING: ALWAYS make sure the saw or stand if used is on a stable dry flat surface before use. NEVER modify the stand or saw structure.

⚠ DANGER: Never touch a live power cord with wet hands. Electrical shock, electrocution, and even DEATH can occur!

WIRING DIAGRAM

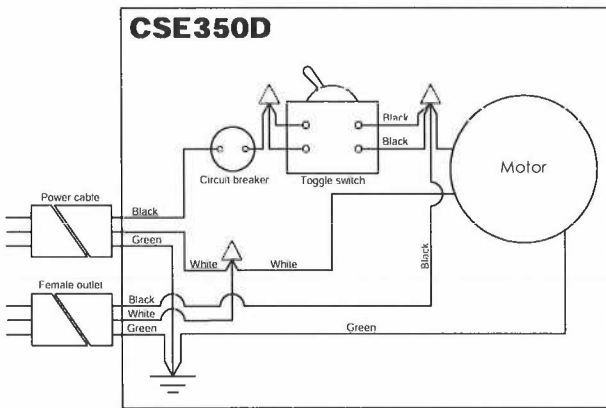

Operating the Saw

⚠ WARNING: Disconnect the power plug before installing or removing the blade or accessories, and before adjusting or making repairs to the power tool.



⚠ WARNING: When using this power tool, use certified safety equipment:

1. Eye protection
⚠ WARNING: Everyday eyeglasses are NOT safety glasses.
2. Hearing protection
⚠ WARNING: Under some conditions and duration of use, noise from this product may contribute to hearing loss.
3. Respiratory protection
⚠ WARNING: Some dust created by power sanding, sawing, grinding, drilling, and other construction activities contains chemicals known to the State of California to cause cancer, birth defects or other reproductive harm. Some examples of these chemicals are:
 - lead from lead-based paints,
 - crystalline silica from bricks and cement and other masonry products, and
 - arsenic and chromium from chemically-treated lumber.
 Your risk from these exposures varies, depending on how often you do this type of work. To reduce your exposure to these chemicals: work in a well ventilated area, and work with approved safety equipment, such as those dust masks that are designed to filter out microscopic particles.

WET CUTTING (optional)

1. After made yourself familiar with the components of your saw, the machine has been properly setup, the garden hose is attached the saw is ready to use.
2. Before you start cutting operation open the water valve on the back of the saw. Water should be flowing onto the blade.
3. Place the cutting material on the table and position it such that the face face of the material sits flush against the cutting fence. Use a rip guide as necessary.
4. Adjust the cutting depth as necessary.
5. Line up the cutting material such that the desired cut lines up with the blade.
6. Turn on the saw and begin cutting. Do not force feed the blade for best cut results.
7. Always turn off the saw before you leave the machine unattended. Unplug the power cable and lock the table at the end of the job.

DRY CUTTING



1. After you made yourself familiar with the components of your saw, the machine has been properly setup, the vacuum table has been assembled, a 50 mm vacuum hose has been attached to the vacuum table and the electrical connection is established in accordance with the relevant safety regulations, the saw is ready to use.
2. Before you start cutting operation turn on the vacuum and ONLY use vacuums with 250 m³/h or stronger.
3. Place the cutting material on the table and position it such that the flat face of the material sits flush against the cutting fence. Adjust the sliding vacuum attachment so it sits flush on the opposite face of the material. Use a rip guide as necessary.
4. Adjust the cutting depth as necessary.
5. Line up the cutting material such that the desired cut lines up with the blade.
6. Turn on the saw and begin cutting. Do not force feed the blade for best cut results.
7. Dress the blade occasionally so the diamonds on the blade do not glaze over.
8. Always turn off the saw before you leave the machine unattended. Unplug the power cable and lock the table at the end of the job.
3. Turn on relevant wet or dry cutting systems.
4. Place the cutting material on the table and position it such that the flat face of the material sits flush against the cutting fence. Use a rip guide as necessary.
5. Lock the cutting table to be at the mid-rail location for plunge cutting. (see figure 13 and 16)
6. Set the cutting head to be at the unlocked state by pulling the angle lock pin head up and turning it 90-degrees so that it remains raised. (see figure 13)
7. Turn on relevant wet or dry cutting systems.
8. Line up the cutting material such that the desired cut lines up with the blade.
9. Turn on the saw and begin cutting by using the plunge handle to pull the blade towards the material on the table. Do not force feed the blade for best cut results.
10. Always turn off the saw before you leave the machine unattended. Unplug the power cable and lock the table at the end of the job.

PLUNGE CUTTING



CAUTION: ALWAYS lock the cutting head in one of three fixed positions when the saw is not in use.

1. Lock the cutting table to be at the mid-rail location for plunge cutting. (see figure 13 and 16)
2. Set the cutting head to be at the unlocked state by pulling the angle lock pin head up and turning it 90-degrees so that it remains raised. (see figure 13)

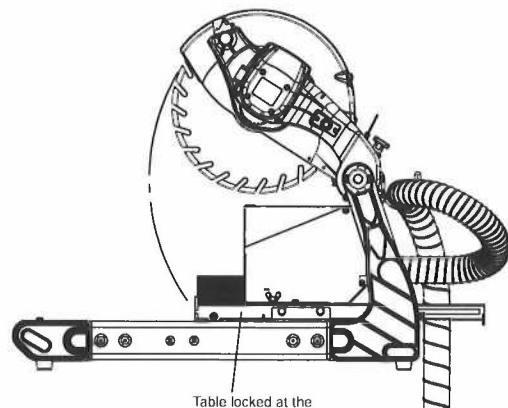
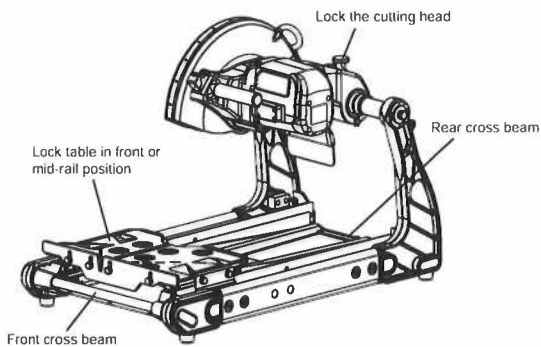

figure 16

Transporting the Saw

⚠ CAUTION: When lifting saw, two people are ALWAYS required. Practice safe lifting behavior when carrying heavy objects. Wear back brace as necessary. DO NOT use open toe shoes.

1. Unplug the power cable and place it within the saw.
2. Make sure the water tray is empty and dry.
3. Lock the cutting table so it is not able to move.
4. Remove any accessories that hang out from the saw and store it within.
5. Lock the cutting head so it does not move.
6. Remove the blade and store it.
7. Lift the saw from the front and rear cross beams of the saw. (see figure 17)



*Actual appearance may vary.

figure 17

Do's & Don'ts For Blades

Wet cutting blades	
DO'S	DONT'S
Inspect blades daily for cracks or uneven wear	Do no operate the saw without safety guards in position
Always use appropriate blade for material being cut	Do not operate the saw with blades other than 350 mm
Unspect arbor shaft for uneven wear before mounting blade	Do not cut dry with blades marked "USE WET"
Always use blades with the correct arbor shaft size	Do not exceed manufacturer's recommended maximum RPM
Ensure that blade is mounted in the correct direction	Do no exceed manufacturer's recommended maximum RPM
Secure the blade to the arbor with wrench	Do no force blade into material--let blade cut at its own speed
Use proper safety equipment with operating the saw	
Periodically check the blade for cracks or bond fatigue	

Dry cutting blades	
DO'S	DONT'S
In addition to the following, always follow wet recommendations	In addition to the following, always follow wet recommendations
Use appropriate blade for material being cut	Do not make long cuts with dry blades--allow them to air cool
Inspect segment blades for segment cracking or loss	Do no use the edge or side of blade to cut or grind
Do not use damaged blades	Do not attempt to cut a radius or curve
User proper safety equipment when operating the saw	Do not cut too deep or too fast into the material
	Do no cut any material not recommended by blade manufacturer

Saw Maintenance

⚠ WARNING: Disconnect the power plug before installing or removing the blade or accessories, and before adjusting or making repairs to the power tool.

⚠ WARNING: Wear eye protection when servicing this power tool.

CLEANING THE SAW AFTER USE

The CSE350D should always be cleaned after use. Steps to follow when cleaning the saw:

1. Do not use aggressive cleaners (i.e. containing solvents). Do not use high-pressure water jets, aggressive detergents or solutions and liquids with a temperature exceeding 30° C! Use lint-free cloth only.
2. Use a cloth which may be lightly moistened only for removing dust and dirt. Hard packed dirt can be removed with a soft brush.
3. For the sake of safety, water/cleaning liquid/vapor may penetrate into the electric motor, connectors/plugs, switches, etc. therefore cover/seal all apertures, holes in the housing, connectors, plugs, with adhesive tape.
4. Use a soft, low-pressure water jet and a brush to rinse dirt and incrustations away. Be particularly careful when near hazardous parts of the machine (i.e. switch, motor, etc...). Clean the vulnerable parts with a moist lint-free cloth.
5. Do not "rinse" the bearings of the drive elements to prevent them from running dry. The ball bearings of the machine are permanently lubricated.
6. After cleaning, remove all areas that were covered/seal by tape! All screws/nuts which you may have loosened must be tightened again!
7. After wet cleaning, plug the machine to a power outlet which is equipped with a ground fault current interrupt (GFCI). If the device cuts power, the machine must be inspected by an authorized dealer prior to use!

DAILY INSPECTION BEFORE USE

Before using the saw it should be checked for any issues. Steps to follow when inspecting the saw:

1. Tighten any loosened threads or bolts and replace any worn or damaged parts.
2. Inspect the blade lock bolt and retighten it if necessary.
3. Check that the roller table is rolling on the rails and that it moves securely back and forth.
4. Check the alignment of the saw head with respect to the table.
5. Check that the air filter is installed.
6. Connect the saw to an electrical power outlet connected to a GFCI. If the device cuts power, DO NOT operate the saw. Have the saw checked by a qualified professional.

TEMPERATURE CHANGES

When ambient temperature drops below 0° C (winter), ALWAYS drain all water from the system including the water tray and pipes.

LONG TERM STORAGE

Before storing the saw for long-term storage, follow these steps:

1. Unplug the saw and secure the power cable to the saw frame with cable ties.
2. Make sure the cutting head is locked in fixed lower position.
3. Clean and lubricate all movings parts. DO NOT grease the guide rails or sealed bearings.
4. Flush out the water system with fresh water and allow all water tubes and trays to dry completely.
5. Lock the cutting table.

AFTER LONG TERM STORAGE

⚠ WARNING: Disconnect the power plug before installing or removing the blade or accessories, and before adjusting or making repairs to the power tool.

After storing the saw for long-term storage, follow these steps:

1. Inspect the rubber feet for excessive wear, cracks, or other damage. Make sure they are properly attached to the saw.
2. Inspect all fastening nuts and bolts for tightness.
3. Inspect the cutting table. Make sure it is properly seated on the guide rails and slides easily along the entire length of the rails.
4. Remove the saw blade and connect the AC power cable and turn the motor ON and OFF quickly. If the motor does not respond, have the saw serviced by an authorized dealer prior to use!

AIR FILTER

⚠ WARNING: Disconnect the power plug before installing or removing the blade or accessories, and before adjusting or making repairs to the power tool.

⚠ CAUTION: Do not run the saw without a filter installed.

⚠ WARNING: Wear approved eye protection when servicing this power tool.

⚠ WARNING: Wear approved respirator protection when handling the air filter.

The filter should be cleaned after every use to maximize motor life. Steps to follow when cleaning the filter:

1. With the motor turned off and the power plug disconnected, carefully check the motor housing to see if it should be allowed to cool before proceeding further.
2. Remove the existing air filter by pulling it out of the inlet of the motor air intake cover. (see figure 18)
3. Remove accumulated dust from the air filter by shaking it or tapping it several times on a hard surface, washing it with warm water, or blowing it with compressed air. If the air filter is damaged, replace it with a new one.

4. Make sure the air filter is completely dry before reinstalling it. If installing a new air filter, inspect it for damage first before use. Insert the air filter through the inlet opening on the motor air intake cover. (see figure 18) The air filter should completely fill the cavity of the motor air intake cover.

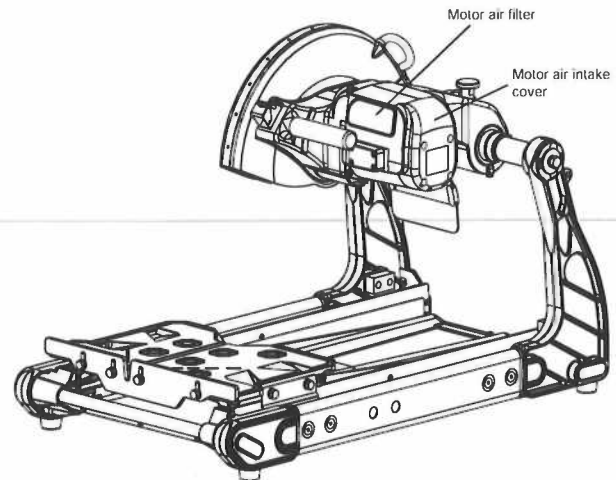

*Actual appearance may vary.

figure 18

CARBON BRUSHES

⚠ WARNING: Disconnect the power plug before installing or removing the blade or accessories, and before adjusting or making repairs to the power tool.

The carbon brushes must be replaced when the brush length becomes less than 11mm and the motor begins to lose power. Steps to follow when changing the carbon brushes:

1. With the motor turned off and the power plug disconnected, carefully check the motor housing to see if it should be allowed to cool before proceeding further.
2. Remove the air filter by pulling it out of the inlet of the motor air intake cover. (see figure 18 and 19)
3. Remove the motor air intake cover by unfastening the four sets of mounting hardware and pulling the cover off. (see figure 19)
4. Remove the carbon brush cover (2) and the carbon brushes (2). (see figure 19)
5. Inspect the armature and the carbon brush holders (2) for excessive wear or damage.

6. Check the carbon brush for uneven wear or chipping. If found the armature or carbon brush holder may be damaged. Do not use and have the saw serviced.
7. Insert the new carbon brushes (2) and remount the carbon brush covers (2). Do not over tighten.
8. Remount the motor air intake cover and relevant hardware. Do not over tighten.
9. Reinsert the air filter.

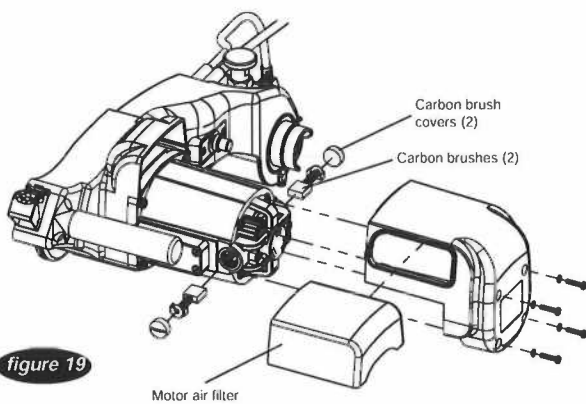
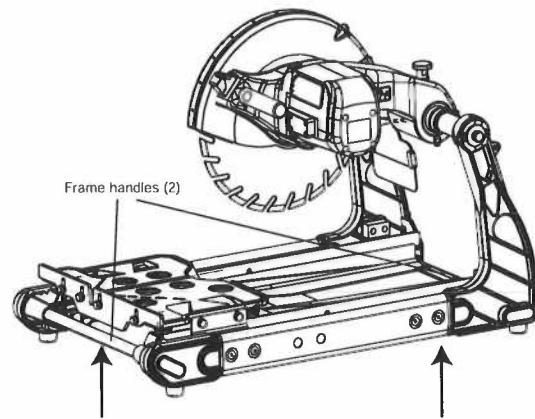

figure 19



*Actual appearance may vary.

figure 20

Transporting the Saw

⚠ WARNING: Disconnect the power plug before installing or removing the blade or accessories, and before adjusting or making repairs to the power tool.

⚠ CAUTION: Practice safe lifting behavior when carrying heavy objects. Wear back brace as necessary. DO NOT attempt to lift the saw by yourself, two people are required. DO NOT use open toe shoes.

Steps to follow when preparing saw for transporting:

1. Make sure the watery tray is empty and dry.
2. Unplug the AC power cable and store it in the water tray
3. Lock the cutting table so it does not move on the rail.
4. Lift the saw and move the saw using the frame handles at the front and rear of the saw. (see figure 24)

Troubleshooting Blade

Symptom	Possible Problem	Solution
Irregular run of saw blade	Poor tension in blade material	Return saw blade to manufacturer
Saw blade wobbles during operation	Saw blade is damaged or bent	Have saw blade aligned/flattened
		Clean receiving (inner) flange
		Replace saw blade
	Saw blade flange is damaged	Replace flange
	Motor shaft is bent	Replace electric motor
Diamond segment becomes loose	Saw blade overheating due to insufficient cooling water (wet cutting)	Replace saw blade and ensure optimum flow of cooling water (wet cutting)
Excessive wear	Wrong type of saw blade	Use harder saw blade
	Motor shaft causes wobbling	Replace motor bearings or motor
	Overheating	Ensure optimum flow of cooling water (wet cutting)
Cracks in or near diamond segment	Saw blade is too hard	Use a softer blade
	Fixed flange is worn out	Have fixed flange replaced
	Motor shaft bearing	Replace motor shaft bearing
Saw blade is blunt	Saw blade type is inappropriate for material being cut	Use appropriate saw blade type
	Saw blade type is inappropriate for saw specifications	
	Saw blade is too hard	
	Diamond segments are blunt	Replace saw blade
Appearance of cut is suboptimal	Poor tension in blade material	Return saw blade to manufacturer
	Too much load placed on saw blade	Use appropriate saw blade type
	Diamond segments are blunt	Replace saw blade
Saw blade arbor hole has widened due to wear	Saw blade has slipped on motor shaft when running	Replace saw blade; make sure arbor hole diameter and blade shaft diameter match
		Check receiving (inner) flange and replace if necessary
Saw blade shows blooming colors	Overheating due to insufficient cooling water (wet cutting)	Ensure optimum flow of cooling water (wet cutting)
	Lateral friction when cutting	Material feed is too high; proceed more slowly

Troubleshooting Saw

Symptom	Possible Problem	Solution
Grinding marks on saw blade	Material not being fed parallel to saw blade	Make sure feed direction is absolutely parallel to saw blade Adjust cutting table/guide rails
	Poor tension in blade material	Return saw blade to manufacturer
	Too much load on saw blade	Material feed is too high; proceed more slowly
Saw does not run when switched on	Power cord not properly fixed/plugged in	Make sure machine is properly connected to power supply
	Defect power cable	Have power cable checked by a qualified electrician; replace if necessary
	Defective main power switch	Have main power switched by a qualified electrician; replace if necessary
	Loose connection within electrical circuit	Have motor checked by a qualified electrician; replace if necessary
	Defective motor	
Motor stops (power cuts out)	Too much pressure exerted while cutting	Exert less pressure while cutting
	Incorrect saw blade specifications	Use appropriate saw blade type
	Defective electrical system	Have the electrical system checked by a qualified technician
Low power/poor machine performance	Power/extension cable is too long or cable is still wound up inside cable drum	Use a correctly rated power cord/extension cable; use a cable drum with cable fully extended
	Power source is insufficient	Verify saw electrical ratings and connect only to a power network that satisfies these requirements
	Electric motor no longer runs at rated speed (RPM)	Have motor checked by a qualified electrician; replace if necessary

DISPOSAL

GENERAL

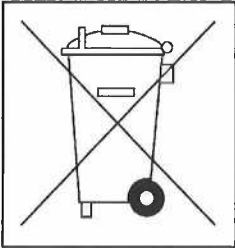

The operator can recycle or dispose of the Table chop saw himself provided he observes the statutory provisions. In order to dismantle the Table saw correctly and to properly remove the materials some knowledge in the area of mechanics and knowledge about differentiation of waste materials is necessary.

If during correct disposal doubts arise that represent a hazard for persons or the environment, the after-sales service of TYROLIT Hydrostress AG will be happy to provide information.



DANGER

Voltage warning

Before working in an area identified in this way, the installation or device must be fully disconnected from the power (voltage) and secured against being accidentally powered up again.

Failure to heed this warning may lead to death or serious injury.

PERSONNEL QUALIFICATIONS

Only personnel with basic technical training and who are in a position to identify the various material groups should be involved in disposal.

DISPOSAL REGULATIONS

The normal local and regional rules and guidelines must be observed when disposing of the machines making up the Table chop saw.

DISPOSAL REGULATIONS

The dismantled parts of the table chop saw are sorted by material and sent separately to the appropriate collection points. Ensure that the following parts in particular are properly disposed of.

The Table chop saw consists of the following materials:

- Cast aluminium
- Rolled aluminium products
- Bronze
- Steel
- Rubber
- Rubber / Nylon fabric
- Synthetic grease
- Plexiglas

OBLIGATION OF NOTIFICATION

When a Table chop saw is taken out of service and disposed of the manufacturer TYROLIT Hydrostress AG or the corresponding service centre must be informed of this.



Konformitätserklärung
Declaration of conformity
Déclaration de conformité
Dichiarazione di conformità
Declaración de conformidad



Wir bestätigen in alleiniger Verantwortung, dass diese Maschine den folgenden Richtlinien und Normen entspricht

We declare under our sole responsibility that this product complies with the following directives and standards

Nous déclarons, sous notre seule responsabilité, que ce produit répond aux directives et norms suivantes

Dichiariamo sotto la nostra completa responsabilità che il presente prodotto è conforme alle seguenti direttive e norme

Declaramos bajo propia responsabilidad que este producto cumple con las siguientes directivas y normas

Angewandte Richtlinie(n)

Directive(s) applied
Directive(s) appliquée(s)
Direttiva/e applicata/e
Directiva(s) aplicada(s)

2006/42/EG	17.05.2006
2011/65/EU	08.06.2011
2012/19/EU	04.07.2012
2014/30/EU	26.02.2014

Angewandte Normen

Applied standards
Normes appliquées
Norme applicate
Normas aplicadas

EN ISO 12100:2010
EN 12418:2000+A1:2009
EN 60204-1:2018
EN IEC 61000-6-2:2019
EN IEC 61000-6-4:2019

Tischsäge
Table saw
Scie de table
Sega da banco
Cortadora de mesa

CSE350



TYROLIT Hydrostress AG

Witzbergstrasse 18
CH-8330 Pfäffikon
Switzerland

Pfäffikon, 17.09.2021

Roland Kägi
Operations + R&D Machines

TYROLIT CONSTRUCTION PRODUCTS GMBH

Swarovskistraße 33 | 6130 Schwaz | Austria

Tel +43 5242 606-0 | Fax +43 5242 63398

Our **worldwide subsidiary companies** can be found
on our website at **www.tyrolit.com**

